

# STANDARD OVERHEAD CONVEYOR CATALOG



Catalog and Design Guide



# Table of Contents

Section	Page	Section	Page
Safe-Rail® .....	4	Inverted Zig-Zag® .....	40
2035 Track .....	5	Inverted Zig-Zag .....	41
Track Connection/Support .....	6	Inverted Pendants .....	42
Horizontal Curves .....	7	Inverted Inspection & Drive Unit .....	43
Standard Ball-Bearing Carriers .....	8	Inverted Take-Up Fittings .....	44
Frog Switches .....	9	Bolt Together Zig-Zag .....	46
Frog Switches .....	10	Zig-Zag Bolt Together .....	47
Throw Controls and Turntables .....	11	Track Connection/Support .....	48
Turntables, Crossovers and		Drive Unit & Inspection .....	49
Carrier Insert Section.....	12	Framed Take-up.....	50
Safe-Rail Layout .....	13	Take-Up Fittings .....	51
Manual Over-Way™ .....	14	Designing a Conveyor .....	52
Track and Curve .....	15	Conveyor Job Worksheet .....	57
Diverter Assembly/Carrier Insert.....	16	2 Year Warranty.....	58
Carrier Assembly .....	17		
Manual Over-Way Layout .....	18		
Zig-Zag® .....	20		
Enclosed Track Conveyor .....	21		
High Performance Conveyor Chain .....	22		
Standard Curves .....	23		
Field Fabricated Curves .....	24		
Framed Take-Up .....	25		
Take-Up Fittings & Expansion Sleeve .....	26		
Drive Units .....	27		
Skeleton Drive .....	27		
System Controls .....	28		
Lubrication and Inspection Section.....	29		
2035 Standard Load Pendants .....	30		
2035 Standard Load Pendants .....	31		
2035 Standard Load Pendants .....	32		
Zig-Zag Stainless & Unpainted Parts .....	33		
Organizer Loop .....	34		
Powered Organizer.....	35		
Suggested Suspension Methods.....	36		
Suggested Suspension Methods.....	37		
Zig-Zag Layout.....	38		

**Richards**-WILCOX

NOTE: We reserve the right to modify or change, without prior notice, any statements or information contained herein. If exact dimensions or specifications are required by the customer, certified prints will be furnished without charge upon request to Richards-Wilcox.





# Safe-Rail<sup>®</sup>

## *INDUSTRIAL TRACK EQUIPMENT*

Four basic components make up a Richards-Wilcox Safe-Rail system:

- Straight track
- Curves
- Switches
- Carriers

Heavy duty enclosed track acts as a runway for the carriers and accommodates loads up to 1,000 lbs. Carriers are manually pushed or gravity fed along the track and can be navigated through hand operated switches to the process areas.

Used extensively in finishing and assembly lines, high density storage, product staging and ergonomic tool support, Safe-Rail is a perfect solution for manipulating awkward and difficult parts throughout production.

These manual systems are typically found in job shops and OEM's that produce a wide variety of parts in relatively low quantities.

# No. 2035 Track

Safe-Rail Systems offer many refinements to make them ideal for the majority of hand push conveyor applications with capacities up to 1,000 lbs. They are available with a complete line of curves, brackets, turntables, crossover switches, lowerators, etc.

The track is basic to Safe-Rail Conveyors. It provides the runway for carriers, and it must carry the loads for the conveyor. Track is painted with Gloss-Tek Powder Coat Finish. 2035.00471 track offers a 7GA. wall thickness, which adds to system life and durability and is the thickest in the industry.

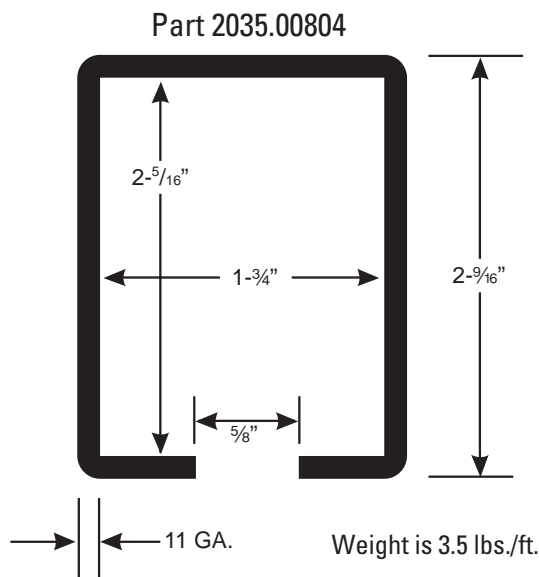
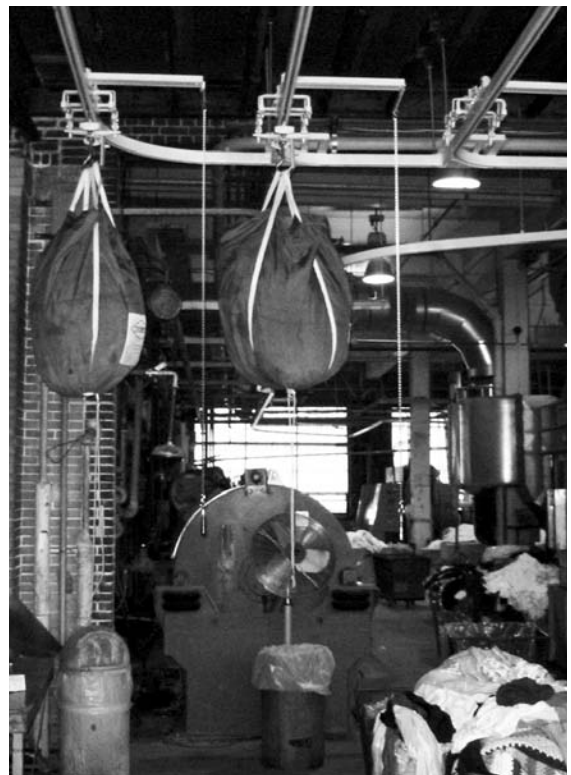
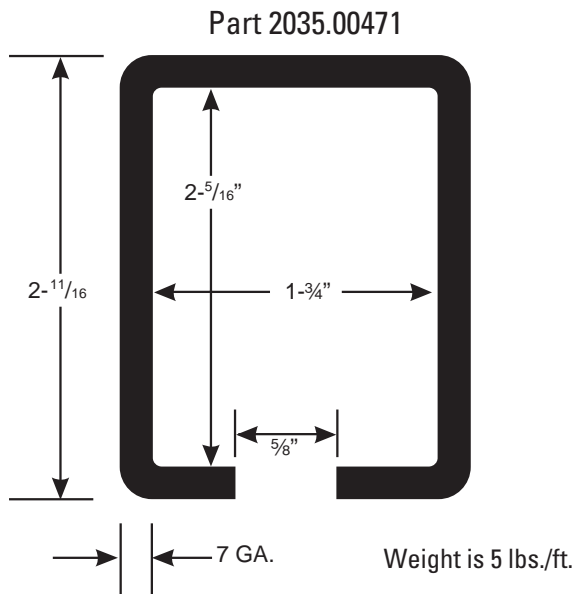

\* Also Available in Stainless Steel.

# Track Connection/Support



2035.00155 Welding Jig in Track

Track sections are connected in two ways:

- By welding, using the 2035.00155 Welding Jig.
- By using the 2035.00021 Wedge Type Joint Bracket.

## Welding

The welding method is recommended since it eliminates the necessity for the joint brackets and makes a continuous section of track. The welding jig aligns the inside of the track, holds the two sections in position for welding, and keeps the weld bead flush with the track to insure smooth operation.

## Track Bracket

The No. 2035.01912 bracket is used only for suspending the track by means of a single bolt. This bracket should be used for supporting the track when the joints are welded and should also be used on curves except when the track is supported by means of angles or flat bars.

Distance top of bracket to bottom of track 3-3/4".



2035.01912 Track Bracket

## Joint Bracket

This bracket holds the sections of track to be joined in perfect alignment. The wedges are drawn together by means of the bolts which go through the sides of the bracket. When these wedges are tightened they securely clamp the sections of track.

This bracket also serves as a suspension bracket.

Distance top of bracket to bottom of track 3-3/4".



2035.00021 Wedge Type Joint Bracket\*

\* This bracket used only with 2035.00471 track

## Spacing of Brackets According to Load

**Single Carriers					
Load in lbs.	125	250	500	1000	
2035.00471 Track	10'0"	10'0"	10'0"	8'0"	
2035.00804 Track	10'0"	NA	NA	NA	
Continuous Loading, Pounds per Foot					
Load in lbs.	125	150	200	250	300
2035.00471 Track	10'0"	8'0"	7'0"	6'0"	5'0"

The table shown above specifies the bracket and drop fitting spacing required for the load shown. Where the table indicates single carriers, reference is made to a situation where only a single carrier may be placed in a specified span.

\*\*Distance between supports.

# Horizontal Curves

Radius*	Part Number
1' 6" (H)	2035.02064
2' 0"	2035.01331
2' 0" (H) (SS)	2035.01352
2' 3" (H)	2035.01354
2' 6"	2035.01833.14
2' 6" (H)	2035.01830.11
2' 9"	2035.01833.15
2' 9" (H)	2035.01830.12
3' 0"	2035.01338
3' 0" (H)	2035.01830.13
3' 3"	2035.01341
3' 6"	2035.01833.18
3' 9"	2035.01833.19
4' 0"	2035.01344
4' 3"	2035.01347
4' 6"	2035.01833.22
4' 9"	2035.01833.23
5' 0"	2035.01833.24
5' 3"	2035.01833.25
5' 6"	2035.01833.26
5' 9"	2035.01833.27
6' 0"	2035.01836.28
6' 3"	2035.01836.29
6' 6"	2035.01836.30
6' 9"	2035.01836.31
7' 0"	2035.01836.32
7' 3"	2035.01836.33
7' 6"	2035.01836.34
7' 9"	2035.01836.35
8' 0"	2035.01836.36
8' 3"	2035.01836.37
8' 4"	2035.01836.52
8' 6"	2035.01836.38
8' 9"	2035.01836.39
9' 0"	2035.01836.40
9' 3"	2035.01836.41
9' 6"	2035.01836.42
9' 9"	2035.01836.43
10' 0"	2035.01836.44
10' 3"	2035.01836.45
10' 6"	2035.01836.46
10' 9"	2035.01836.47
11' 0"	2035.01836.48
11' 3"	2035.01836.49
11' 6"	2035.01836.50
11' 9"	2035.01836.51

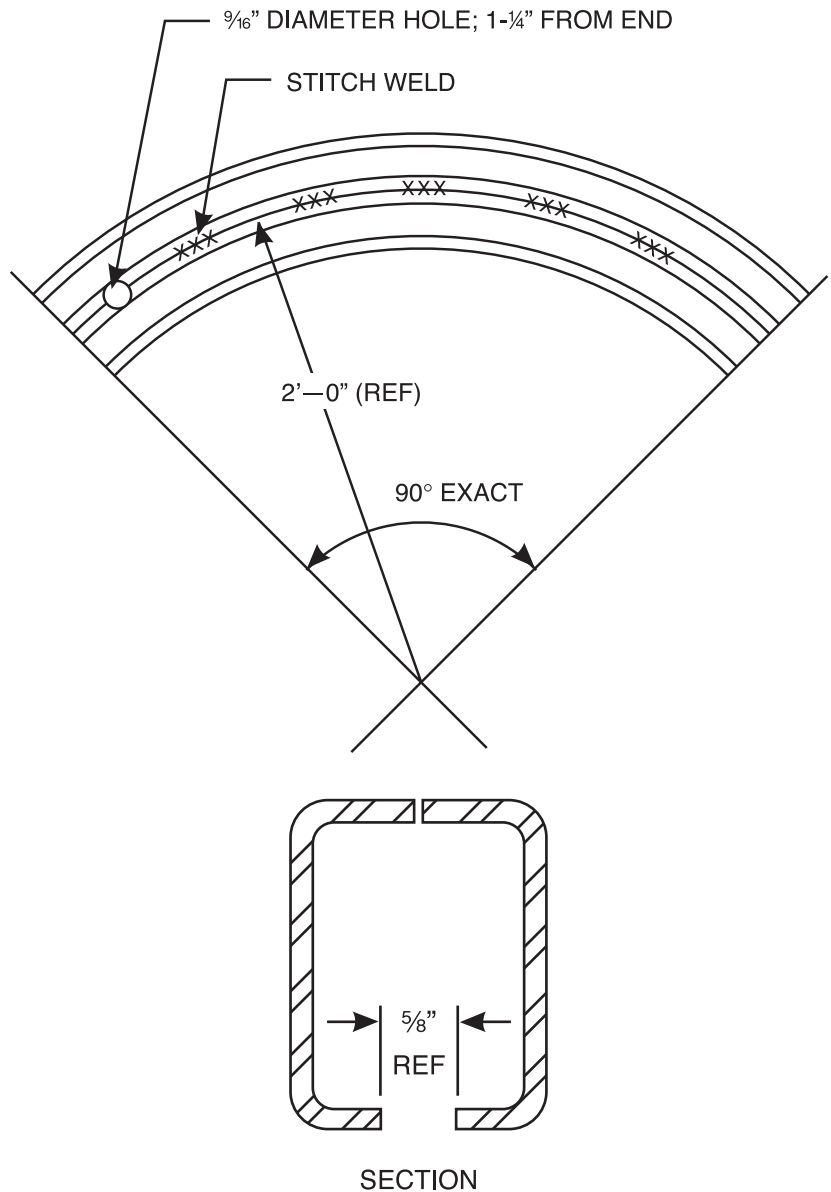

(SS) = Stainless Steel  
 (H) = Hardened Component

\*NOTE: Curves up to 5' 9" radius furnished in 90°. Curves from 6' 0" to 11' 9" radius furnished in 45° sections.



# Standard Caged Ball-Bearing Carriers

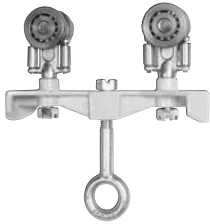

2035.00234

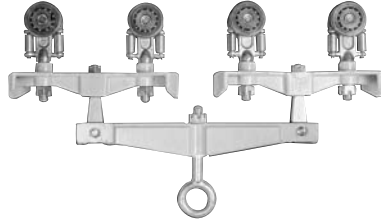

2035.00236

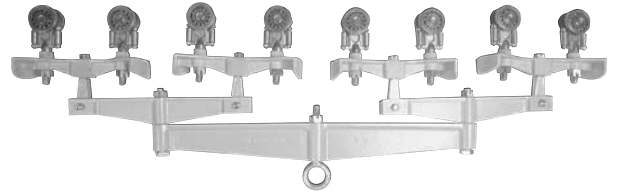

2035.00240

Carrier No.	Capacity Pounds	Diameter of Wheels, Inches	Length Overall, Inches	Bottom of Track to Bottom of Eye of Stem, Inches	EYEBOLT Diameter, Inches		Weight, Pounds
					Stem	Eye	
2035.00234	250	2-1/8"	10"	5-3/8"	1/2"	1-1/2"	6
2035.00236	500	2-1/8"	22"	9"	5/8"	1-1/2"	1
2035.00240	1000	2-1/8"	46"	12-1/2"	3/4"	1-3/4"	38
2035.00563*	125	2-1/8"	2-3/8"	3-1/4"	1/2"	—	1.4
2035.01710	125	2-1/8"	2-3/8"	3-5/8"	5/8"	—	1.5
2035.01718	250	2-1/8"	5"	2-3/4"	—	1-1/4"	2.5
2035.00570	250	2-1/8"	10"	—	—	—	7
2035.00569	250	2-1/8"	16-3/8"	—	—	—	11

\*1/2" Pendant. All other assemblies on this page have 5/8" diameter pendants.



2035.01710  
2035.00563\*\*



2035.01718



Typical  
Cross-Section

All carriers are equipped with machined steel wheels. All have full complement steel caged ball bearings. Wheel pendants are drop forged and equipped with hardened machine steel thrust rollers. Load bars are malleable iron castings complete with bumpers as illustrated. The eyes are drop forged and heat treated. Carrier load bars are finished with Gloss-Tek Powder Coat.

## 4 Wheel Twin-Trak™ Carriers

This carrier is designed for use with pusher conveyors only. It is equipped with a standard pusher arm as shown.

The 2035.00570 carrier with its shorter wheelbase spaces the product on 10" minimum centers.

The 2035.00569 carrier with its longer wheelbase spaces the product on 16-3/8" minimum centers.



2035.00570  
10" Overall Length

2035.00569  
16-3/8" Overall Length



# Frog Switches

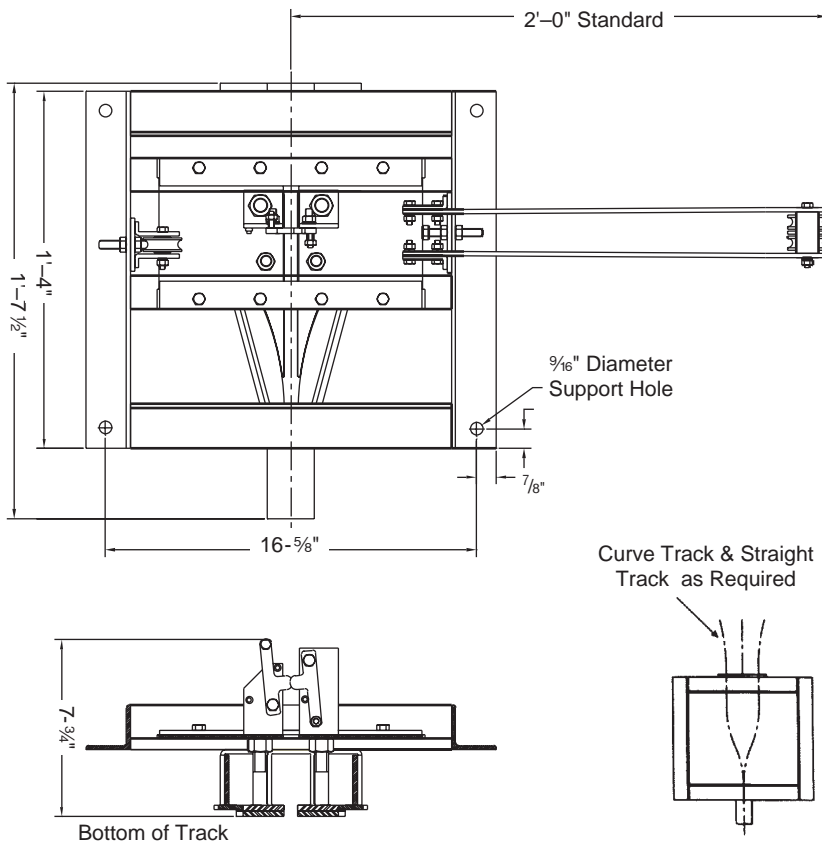

## 2035.00795 Manual Three-Way Frog Switch

The Three-Way Manual Frog Switch is similar in design to the two-way Universal Radius Frog Switch. The main difference is that the three-way switch has two movable frog plates that can be switched between three positions in the track. The position of the frog plates is controlled by two chains attached to the frog plates through a pulley system. Pulling one chain shifts the switch to the left-hand position; pulling the other chain shifts the switch to the right-hand position. Pulling both chains shifts the switch to the center position. The throw control is included with the switch and extends 2'-0" from the centerline of the main track.

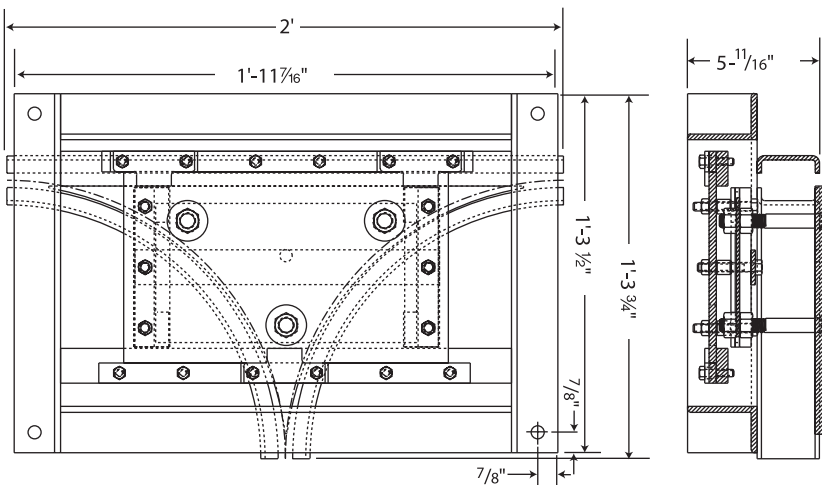

## 2035.01396 "T" Manual Frog Switch

The Three-Way "T" Frog Switch is a rugged unit with a full frog throw of 5/8". Carrier movement through the switch is smooth and unhampered as a result of the die-formed frog plate, which allows a line-to-line fit of the matching parts. Wide track gaps, present in most designs, are eliminated. The switch has two 12" radius x 90° curve for carriers with a wheelbase of 12" or less. With carriers with a wheelbase longer than 12", or where the angle is less than 90°, Universal Frog Switches are recommended. This Three-Way "T" Switch must be manually shifted from one position to another. Most commonly, a suitable actuator is used by the operator to engage the hole in the bottom of the frog plate.

The Three-Way "T" Frog Switch provides the means of moving a carrier left, right, or across in a "T" configuration, rather than the left, right, or straight provided by the universal switches.

# Throw Controls and Turntables

## 2035.00620 Switch Throw Controls

For part number 2035.00618, 2035.00619, 2035.00698 and 2035.00699 Frog Switches

2035.00620 Switch Throw Control permits selective control of carriers being placed into a spur line. When using the above switches as a feed-in device (such as going from a main line into a spur track), it is necessary to use a throw control. It is not necessary when used as an escapement. 2035.00620 control is shipped ready for mounting except for the extension arms.

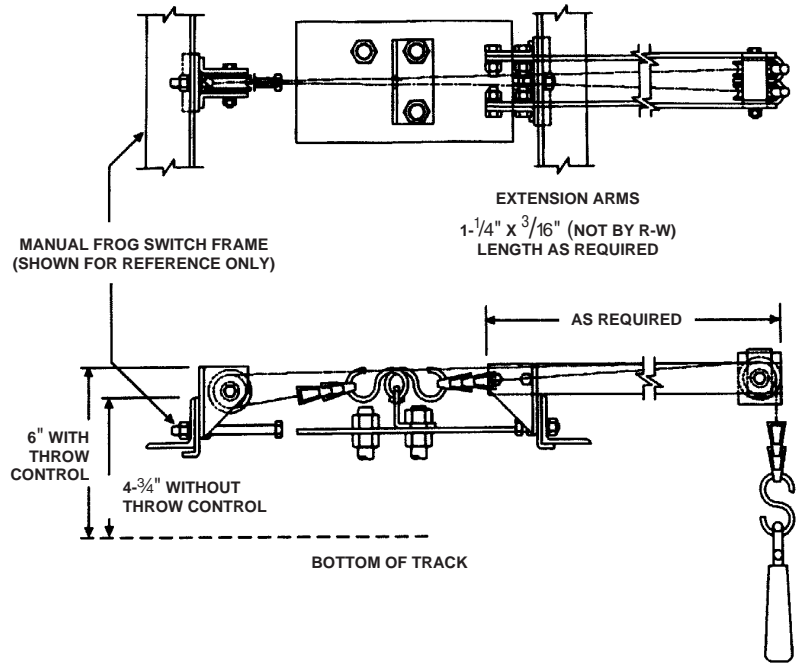

## 2035.00843 Turntable 12" Gap

The turntable illustrated is a basic unit with a 12" gap. The unit has a maximum capacity of 250 lbs. This is a fabricated steel unit with the center section turning on ball bearings. This unit turns the load 90° and may be used for any 4-wheel carrier less than 12" in length.

The tandem arrangement shown below is accomplished by applying a dual control mechanism to two of the basic 2035.00843 units. Tandem control permits the simultaneous turning of two carriers connected by a load bar.

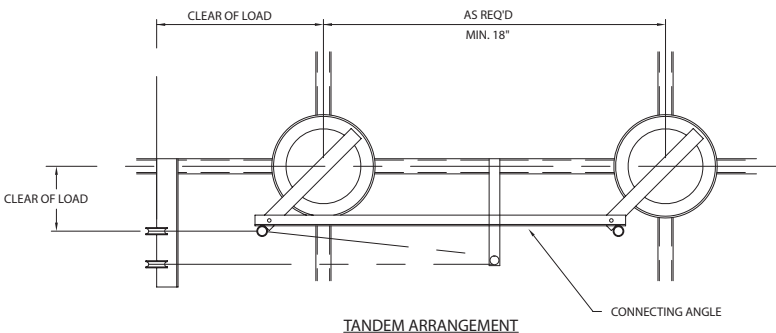
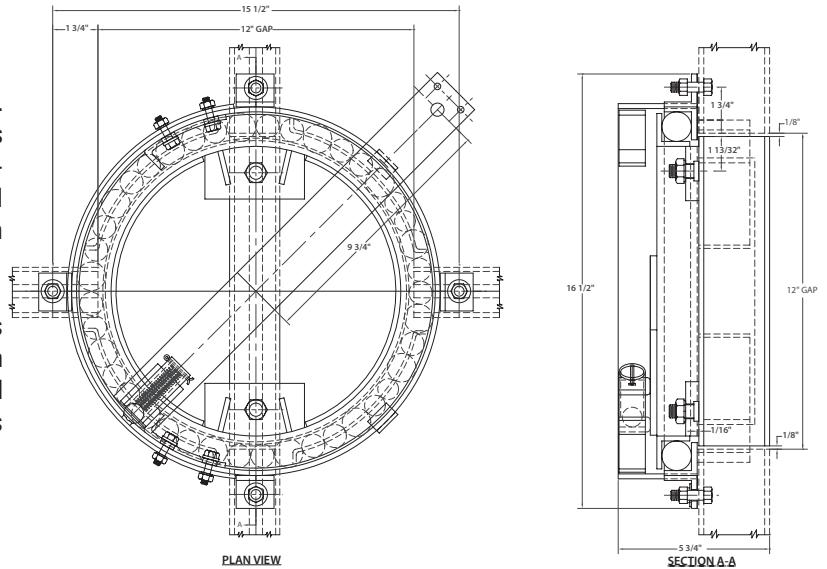

## Turntables, Crossovers and Insert Section

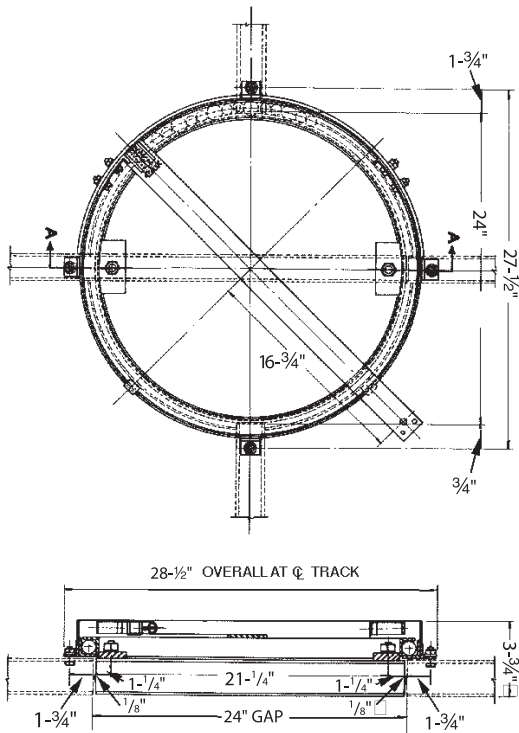

2035.00821 Turntable 24" Gap

### 2035.00821 Turntable 24" Gap (Shown)

The 2035.00821 Turntable is manufactured with a standard 24" gap. The unit has a maximum capacity of 500 lbs.; it is a fabricated steel unit with the turning section carried on eight ball bearing wheels. This unit turns the load 90° and is equipped with plunger type latches actuated by a pull chain control. The 2035.00825 Throw Control is available to shift the turntable.

### 2035.00311 Crossover (Not Shown)

The 2035.00311 Crossover should not be confused with a turntable. This unit incorporates a 6" section of movable track which is turned at the point of intersection of four tracks. The unit is not to be used for changing the direction of the carrier; as the name implies, it is solely for crossover purposes.

## Carrier Insert Section

### 2035.00705 Carrier Insert Section

The insert section is used in every system to introduce carriers and is the only means for introducing carriers into the track. For easy accessibility it is recommended that it be located in a low straight track section.

NOTE: Make sure bolts are in place before operation.



# Typical Safe-Rail

## 2035 Safe-Rail Conveyors

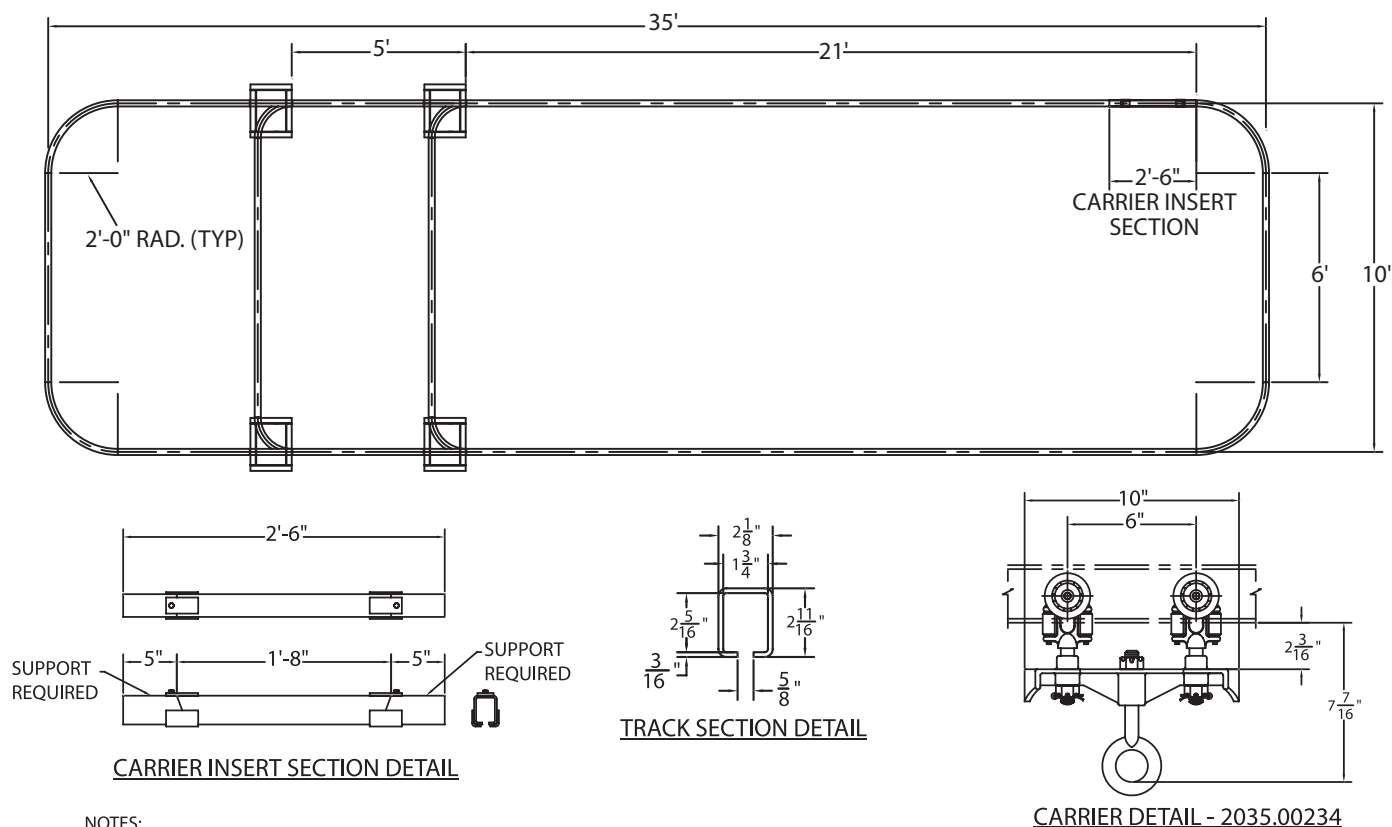

**NOTES:**

- 1) TWENTY (20) CARRIERS REQUIRED
- 2) PRODUCT LOAD ~ 250 LBS EACH

### Bill Of Material

QUANTITY	ITEM NUMBER	DESCRIPTION
1	2035.00155	WELDING JIG
16	2035.00021	OH JOINT BRACKET (Optional)
10	2035.01912	OH PLAIN BRACKET (Optional)
9	2035.00471	TRACK, 7 GA, 10'-0" LENGTH
1	2035.00705	CARRIER INSERT SECTION
4	2035.01331	HORIZONTAL CURVE, 2'0" R X 90 DEGREE
2	2035.00618	LEFT HAND FROG SWITCH
2	2035.00619	RIGHT HAND FROG SWITCH
20	2035.00234	FOUR WHEEL CARRIER (250 lbs. cap)
4	2035.00620	MANUAL THROW CONTROL



# Manual OveR-Way<sup>®</sup>

Manual OveR-Way conveyor systems are designed for hand-push transport when loads exceed 1000 pounds. Using components originally developed for OveR-Way Power & Free, Manual OveR-Way allows a high capacity solution when power is not necessary to maneuver heavy loads through a system.

The components are manufactured with two 3" toe-to-toe channels supported with yokes, but does not include the enclosed track above the channels. Carriers use standard OveR-Way intermediate trolleys connected to axles which support the main load bar. Manual OveR-Way components are pre-welded at the factory to ensure unparalleled precision.

Some benefits of Manual OveR-Way are floor space utilization and reduction of product damage and worker injury. Manual OveR-Way can also be upgraded to OveR-Way Power & Free or combined with an OveR-Way Power & Free system in areas where worker manual interface is necessary.

# Track and Curve

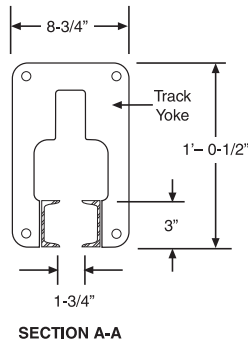
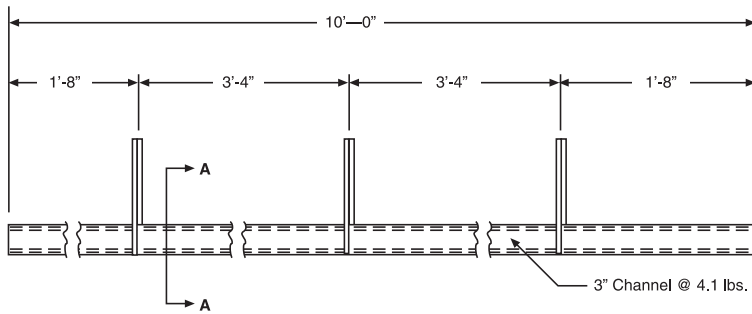

## 3035.00177 2000 LB. Load Capacity - Over-Way Straight Track Section (No Power)

The Over-Way Straight Track Section (no power) consists of 3" channels welded to the plate steel yokes. The track is furnished in 10'-0" nominal lengths and painted with Gloss-Tek standard powder coat finish.

Yokes are configured to allow for future automation of the manual Over-Way.

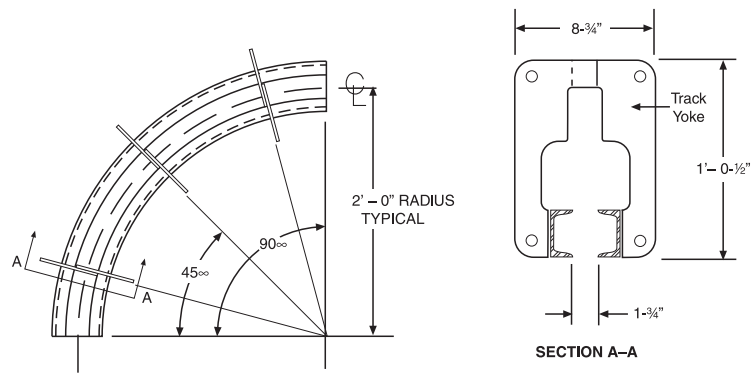

## 3035.00265 and 3035.00222 Curve Channel Assemblies (No Power)

The Over-Way horizontal curve assemblies (no power) are available in 2' - 0" radius by 90° and 45°. The curve assemblies are painted with Gloss-Tek powder coat finish.

Yokes are configured to allow for future automation of the manual Over-Way.

3035.00265 Curve Channel Assembly

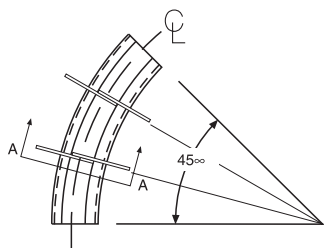

3035.00222 Curve Channel Assembly

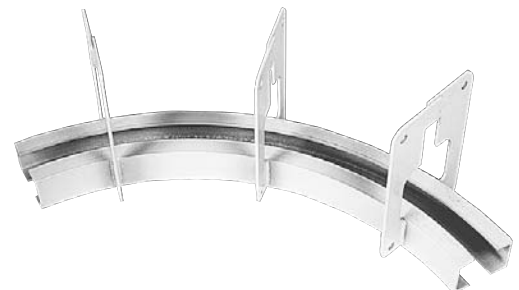



# Diverter Assembly

## Diverter Assembly (No Power)

3035.00216 (Right-Hand)

3035.00218 (Left-Hand)

This diverter is normally used in an Over-Way system to allow the carrier assembly to move from the main line to a spur line. The assembly is provided with a pivoting tongue which allows the trolley wheels to follow the straight path or the curved path. When used to enter a spur line, the pivoting tongue is normally operated by a manual throw control (3035.00057), but can be operated by an air package (3035.00160, 24V or 3035.00267, 110V).

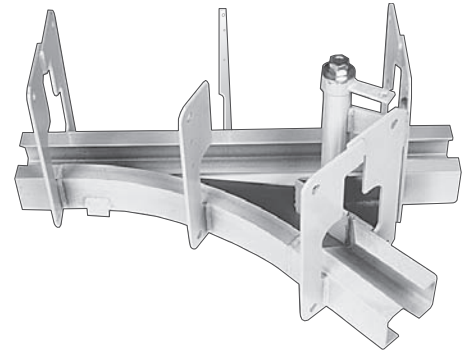

The diverter is painted with Gloss-Tek powder-coat finish.

Yokes are configured to allow for future automation of the manual Over-Way.

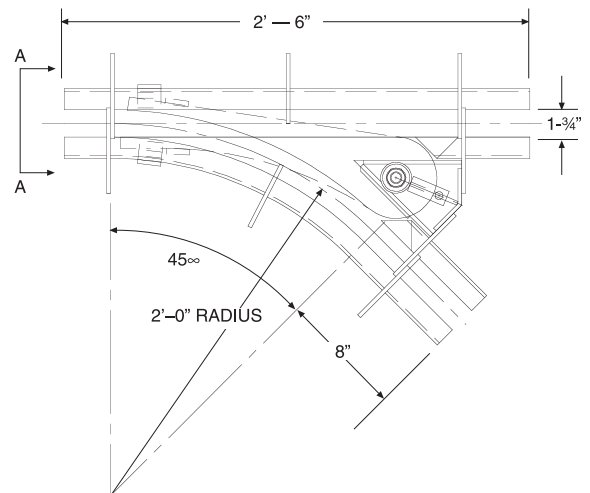
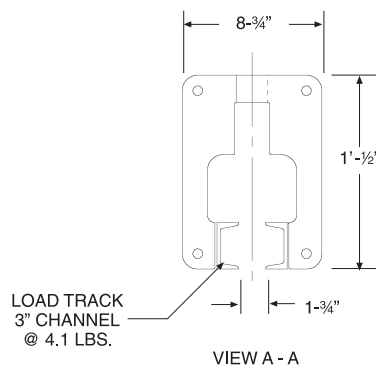

## Carrier Insert Section

The Over-Way Carrier Insert Section is used to insert new carriers into the conveyor system, or take existing carriers out of the conveyor system for maintenance purposes.

The track section is painted with Gloss-Tek powder-coat finish.

Yokes are configured to allow for future automation of the manual Over-Way.

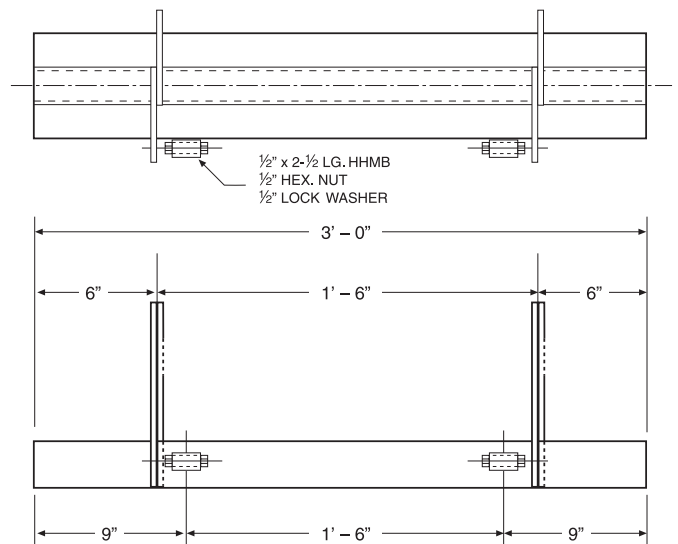
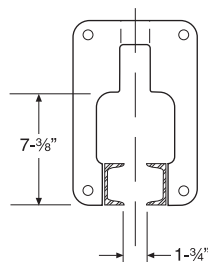

# Carrier Assembly

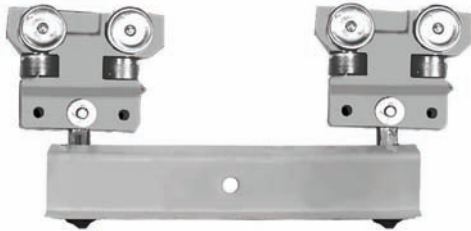

## Manual Over-Way Carrier Assembly

The Manual Over-Way Carrier Assembly consists of two standard 3035.00729 trolleys which are connected to a load bar with load bar axles (3035.00719.01).

The Carrier Assembly, as shown, has a capacity of 1,000 lbs. (Can accommodate a 2,000 lb. load when two carrier assemblies are used with a specified load bar. See Below.)

NOTE: Trolleys are provided with sealed re-greasable bearings.

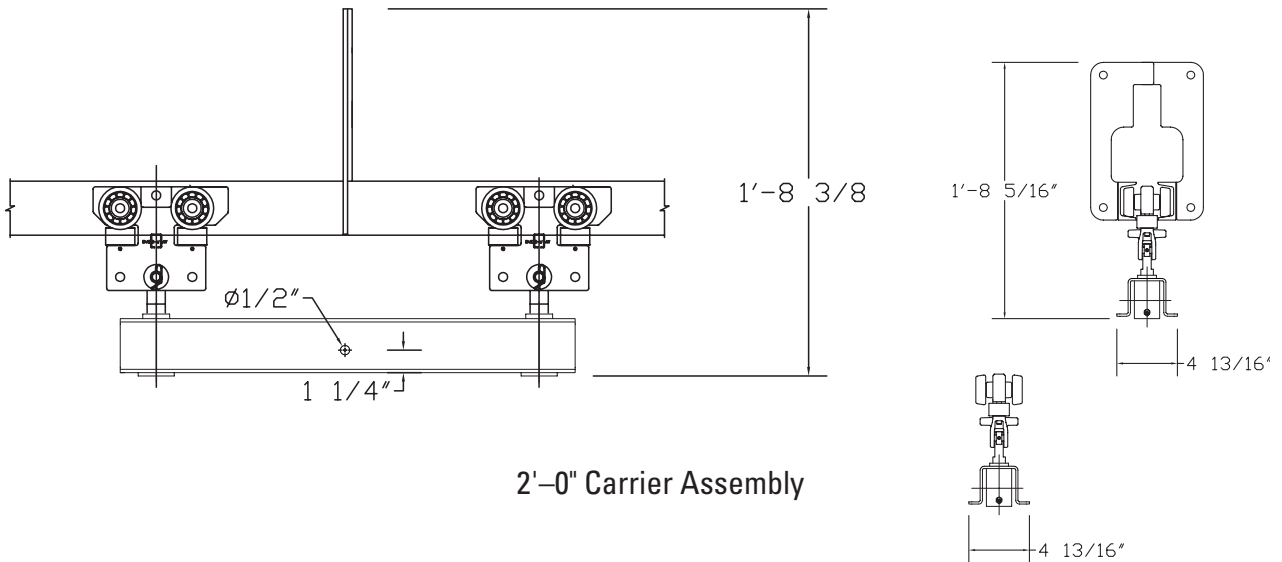

# Typical Manual Over-Way Layout

## 2035 Manual Over-Way Conveyors

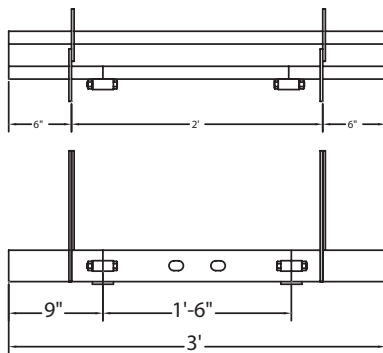
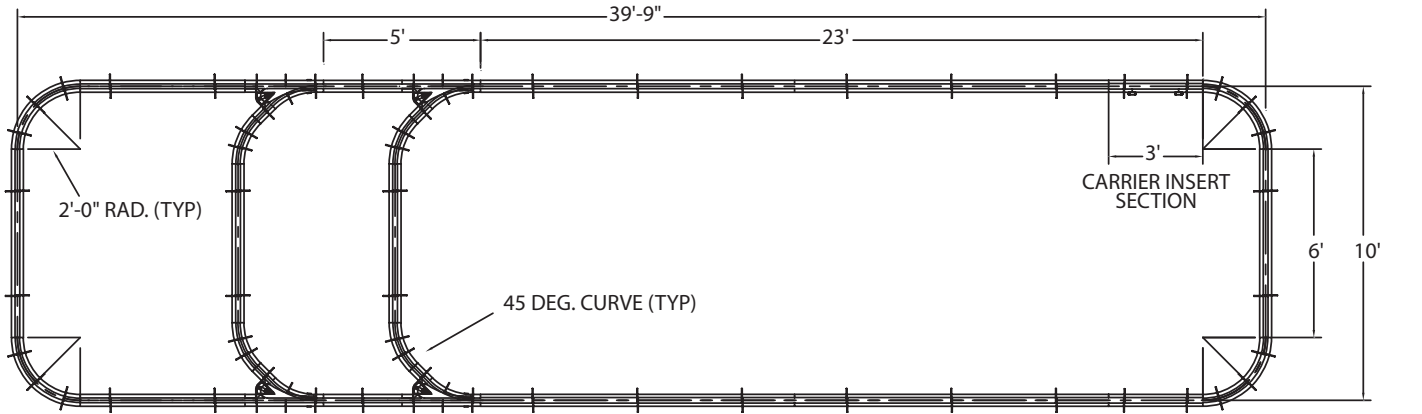

CARRIER INSERT SECTION DETAIL

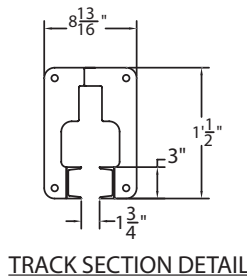

TRACK SECTION DETAIL

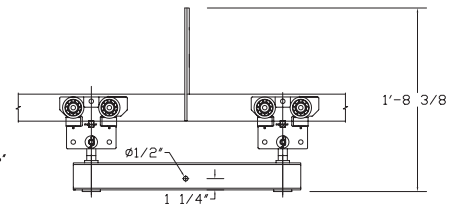
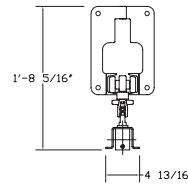

CARRIER DETAIL

## Bill Of Material

QUANTITY	ITEM NUMBER	DESCRIPTION
9	3035.00177	TRACK SECTION 10'-0" lg - NO POWER
6	3035.00181	HALF YOKE
1	3035.00013	OVER-WAY CARRIER INSERT SECT.
4	3035.00265	HORZ. CURVE 2'-0"R - 90 DEG - NO POWER
4	3035.00222	HORZ. CURVE 2'-0"R - 45 DEG - NO POWER
2	3035.00216	DIVERTER ASSEMBLY RIGHT HAND - NO POWER
2	3035.00218	DIVERTER ASSEMBLY LEFT HAND - NO POWER
2	3035.00057	MANUAL THROW OPERATION PKG FOR DIVERTER
20	3035.00729	REAR TROLLEY, RLR BEARING GUIDE (GREASE)
10	3035.00023.01	LOAD BAR ASSEMBLY 2'0" CARRIER
20	3035.00719.01	LOAD BAR AXLE, 5 1/2" LONG (2 required per load bar)
20	3035.00633	CLEVIS PIN 1/2" DIAMETER x 1 3/4" LONG (2 per Load Bar)
20	023671	WASHER, 1/2 FLAT, ZC (2 Per Load Bar)
20	094051	1/8" X 1" COTTER PIN (2 Per Load Bar)





# Zig-Zag<sup>®</sup>

## ***2035 CONTINUOUS OVERHEAD POWER CHAIN CONVEYOR***

Zig-Zag gets its name from its ability to navigate up, down, around, and through various points in a production facility or distribution center.

In a Zig-Zag system parts, totes, or boxes continuously move along the track at an adjustable speed to fit the application.

Products are suspended by pendants secured to the moving chain. Pendants can be 6" apart and are capable of carrying up to 75 lbs. each. Parts can be hung from multiple pendants to increase the load capacity.

Zig-Zag systems are very simple and economical for upgrading to an automated material handling solution.

Zig-Zag is typically used in finishing, assembly, high density storage, product staging, ergonomic tool support, and for high speed tote/carton delivery and trash removal systems in order fulfillment and distribution centers.

# Zig-Zag

## The Original Enclosed Track Conveyor

Richards-Wilcox Zig-Zag conveyor is constructed of standard modular components that guarantee easy installation, modification, and maintenance.

### Features:

#### Eleven Standard Components

- Straight Track, 7 GA. thick in 10' lengths
- Welding Jig
- Horizontal Curves, 7 GA. thick, 90°, flame hardened
- Top Vertical Curves, 7 GA. thick, 90°, flame hardened
- Bottom Vertical Curves, 7 GA. thick, 90°, flame hardened
- Conveyor Chain, 6" pitch
- Take-up Assembly
- Inspection Section
- Chain Oiler
- Standard Drive Packages
- Load Pendant Attachments

#### Vertical Chain Wheels on 6" Centers

- Spread the same amount of load over more wheels
- Reduce the point loading on track and reduce wear

#### Capacities

- 75 lbs. per load pin
- Standard drive packages up to 750 lb. chain pull



# High Performance Conveyor Chain

## 2035.01974HP High Performance Conveyor Chain

This chain is designed for maximum flexibility. It is made up of a series of alternating vertical wheels and lateral roller units with the vertical wheels on 6" centers. These units are assembled to make up a universal joint-like chain which operates around short-radius vertical or horizontal curves with equal success. The vertical wheels consist of machined wheels with precision alloy caged steel ball bearings. The vertical wheels carry the load and roll on the bottom of the track except when negotiating bottom vertical curves, then they bear against the top of the track. The lateral unit is manufactured in the same manner as the vertical wheel and is assembled into a forged steel link. The machined wheels roll against the sides of the track when going around horizontal curves. The vertical and lateral units are connected by means of alloy pins and hardened steel rollers which take the thrust in either direction. The chain is detachable at any point. The chain is preassembled in 10-foot coils or 300-feet in a crate.

### Features

#### 6" Pitch

High Performance Conveyor Chain has a pitch of 6" and is the shortest in the industry. This allows up to 33 percent more productivity. The pitch of our chain allows you to space load pendants closer with less wheel loading, allowing for more product throughput. This shorter pitch also allows for tighter radius horizontal curves. Richards-Wilcox can provide standard stock 18" radius horizontal curves.

#### Load Pin

High Performance Conveyor Chain is manufactured with a pendant load pin. Unlike some competitors, Richards-Wilcox pendants are mounted to a load pin and not the wheel axle. This eliminates unnecessary wear and torsional loads to critical parts of the chain, thereby increasing your productivity and decreasing your downtime.

#### Installation and Maintenance

By design, High Performance Conveyor Chain is made for ease of installation and maintenance. Our chain may be disassembled at any point by simply removing a cotter pin.

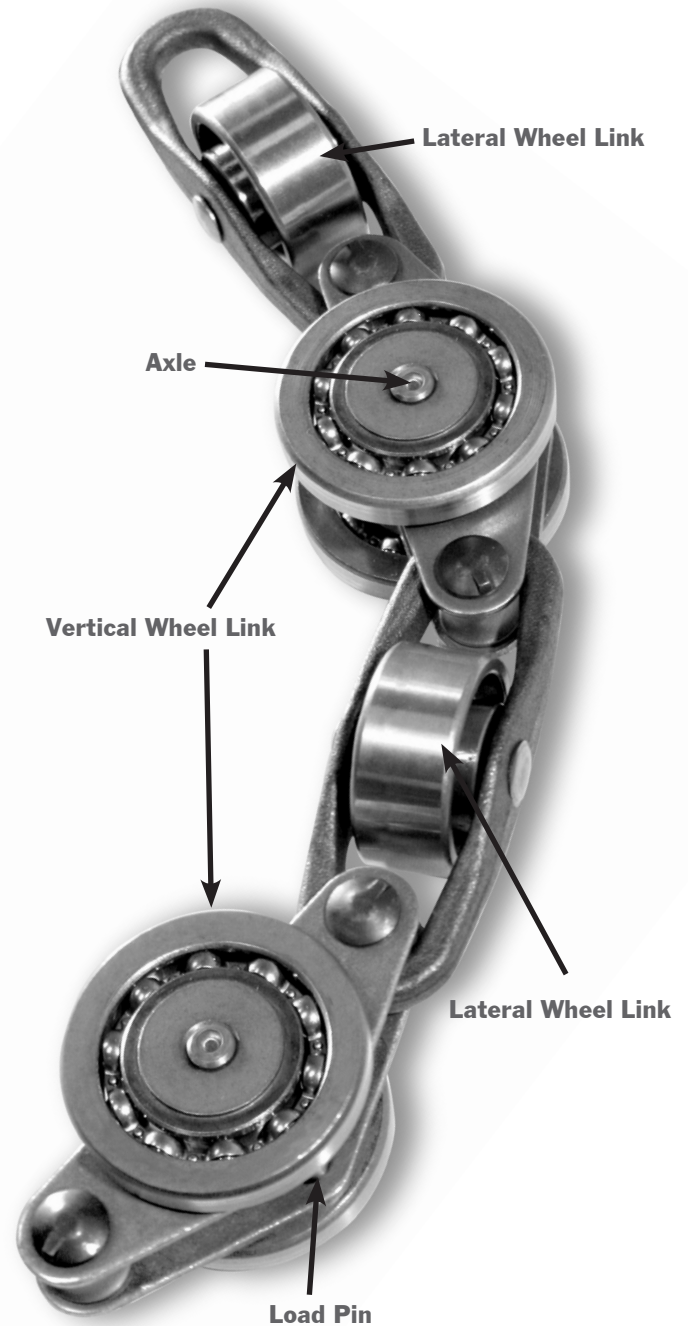

### ADVANTAGES

- Longer Chain Life
- Smoother Operation
- Quieter Operation
- Less Downtime
- Greater Reliability

### BENEFITS

- Lower replacement frequency
- Reduced system drag for increased system life
- More ergonomic, easier on workers
- Improved efficiencies
- Cheaper maintenance and lower total system costs

# Standard Curves

## Vertical Curves

On vertical curves the chain wheels bear against the inside of the track and contact the top of the track on bottom curves and the bottom of the track on top curves. The chain, in this way, is guided around short radius vertical curves.

## Horizontal Curves

The chain passes around horizontal curves without the use of special guides, sprockets, or wheel turns.

The lateral wheels bear on the side of the track when the chain is drawn around curves. A series of wheels constantly share the load imposed upon the track, thereby reducing friction and ensuring smooth conveyor operation.

Curves with these radii are standard:  
1'-6", 2'-0", 2'-3", 3'-0", 3'-3", 4'-0" and 4'-3".

NOTE: All curves up to 3'-0" are available hardened for increased life and made of heavy-duty 7GA. material, the heaviest in the industry.



2035.02757 & 2035.02756  
Top Vertical Curve 45° & 30°



2035.00980 Top  
Vertical Curve 90°



2035.01352  
Horizontal Curve 90°



2035.02756 & 2035.02748  
Horizontal Curve 45° & 30°



2035.00981 Bottom  
Vertical Curve 90°



2035.02010	Traction Wheel 36" Diameter
2035.02011	Traction Wheel 30" Diameter
2035.02012	Traction Wheel 24" Diameter



2035.02759 & 2035.02758  
Bottom Vertical Curve 45° & 30°



# Field Fabricated Curves

## Vertical Curve Data

NOTE: The Vertical Curve dimensions in the chart below are based on using 2'-0" radius curves.

45°, 2'-0" radius vertical curve shown.

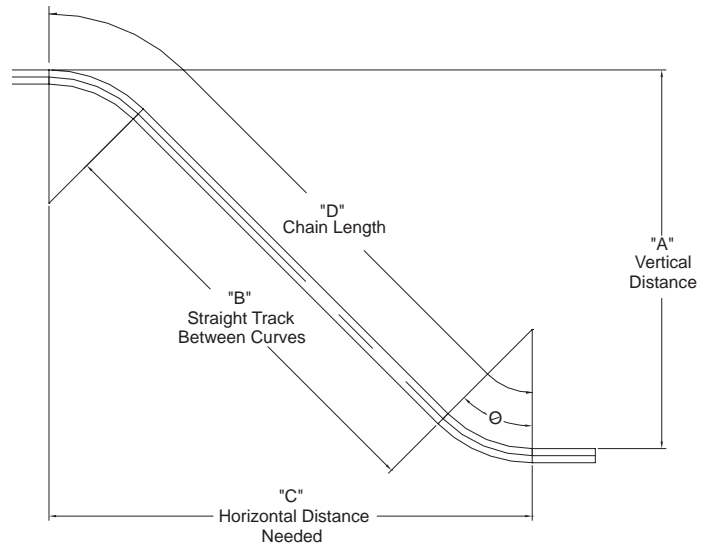

30°				45°			60°		
A	B	C	D	B	C	D	B	C	D
6 <sup>7</sup> / <sub>16</sub> "	0'-0"	2'-0"	2'-1 <sup>1</sup> / <sub>8</sub> "	—	—	—	—	—	—
9"	0'-5 <sup>1</sup> / <sub>8</sub> "	2'-4 <sup>7</sup> / <sub>16</sub> "	2'-6 <sup>1</sup> / <sub>4</sub> "	—	—	—	—	—	—
12"	0'-11 <sup>1</sup> / <sub>8</sub> "	2'-9 <sup>5</sup> / <sub>8</sub> "	3'-1 <sup>1</sup> / <sub>4</sub> "	—	—	—	—	—	—
1'-2"	1'-3 <sup>1</sup> / <sub>8</sub> "	3'-1 <sup>1</sup> / <sub>8</sub> "	3'-4 <sup>1</sup> / <sub>4</sub> "	1 <sup>1</sup> / <sub>16</sub> "	2'-9 <sup>15</sup> / <sub>16</sub> "	3'-1 <sup>11</sup> / <sub>16</sub> "	—	—	—
1'-6"	1'-11 <sup>1</sup> / <sub>8</sub> "	3'-8 <sup>1</sup> / <sub>16</sub> "	4'-1 <sup>1</sup> / <sub>4</sub> "	5 <sup>9</sup> / <sub>16</sub> "	3'-1 <sup>7</sup> / <sub>8</sub> "	3'-7 <sup>1</sup> / <sub>4</sub> "	—	—	—
1'-9"	2'-5 <sup>1</sup> / <sub>8</sub> "	4'-1 <sup>1</sup> / <sub>4</sub> "	4'-6 <sup>1</sup> / <sub>4</sub> "	9 <sup>13</sup> / <sub>16</sub> "	3'-4 <sup>7</sup> / <sub>8</sub> "	3'-11 <sup>1</sup> / <sub>2</sub> "	—	—	—
2'-0"	2'-11 <sup>1</sup> / <sub>8</sub> "	4'-6 <sup>7</sup> / <sub>16</sub> "	5'-1 <sup>1</sup> / <sub>4</sub> "	1'-2 <sup>1</sup> / <sub>16</sub> "	3'-7 <sup>7</sup> / <sub>8</sub> "	4'-3 <sup>3</sup> / <sub>4</sub> "	0'-1 <sup>1</sup> / <sub>16</sub> "	3'-5 <sup>9</sup> / <sub>16</sub> "	4'-2 <sup>1</sup> / <sub>4</sub> "
2'-3"	3'-5 <sup>1</sup> / <sub>8</sub> "	4'-11 <sup>5</sup> / <sub>8</sub> "	5'-6 <sup>1</sup> / <sub>4</sub> "	1'-6 <sup>5</sup> / <sub>16</sub> "	3'-10 <sup>7</sup> / <sub>8</sub> "	4'-8"	0'-3 <sup>7</sup> / <sub>16</sub> "	3'-7 <sup>5</sup> / <sub>16</sub> "	4'-5 <sup>3</sup> / <sub>4</sub> "
2'-6"	3'-11 <sup>1</sup> / <sub>8</sub> "	5'-1 <sup>13</sup> / <sub>16</sub> "	6'-1 <sup>1</sup> / <sub>4</sub> "	1'-10 <sup>9</sup> / <sub>16</sub> "	4'-1 <sup>7</sup> / <sub>8</sub> "	5'-1 <sup>1</sup> / <sub>4</sub> "	0'-6 <sup>15</sup> / <sub>16</sub> "	3'-9 <sup>1</sup> / <sub>16</sub> "	4'-9 <sup>3</sup> / <sub>16</sub> "
2'-9"	4'-5 <sup>1</sup> / <sub>8</sub> "	5'-10"	6'-6 <sup>1</sup> / <sub>4</sub> "	2'-2 <sup>13</sup> / <sub>16</sub> "	4'-4 <sup>7</sup> / <sub>8</sub> "	5'-4 <sup>1</sup> / <sub>2</sub> "	0'-10 <sup>3</sup> / <sub>8</sub> "	3'-10 <sup>3</sup> / <sub>4</sub> "	5'-1 <sup>1</sup> / <sub>16</sub> "
3'-0"	4'-11 <sup>1</sup> / <sub>8</sub> "	6'-3 <sup>3</sup> / <sub>16</sub> "	7'-1 <sup>1</sup> / <sub>4</sub> "	2'-7 <sup>1</sup> / <sub>16</sub> "	4'-7 <sup>7</sup> / <sub>8</sub> "	5'-8 <sup>3</sup> / <sub>4</sub> "	1'-1 <sup>7</sup> / <sub>8</sub> "	4'-1 <sup>1</sup> / <sub>2</sub> "	5'-4 <sup>1</sup> / <sub>8</sub> "
3'-6"	5'-11 <sup>1</sup> / <sub>8</sub> "	7'-1 <sup>5</sup> / <sub>8</sub> "	8'-1 <sup>1</sup> / <sub>4</sub> "	3'-3 <sup>1</sup> / <sub>2</sub> "	5'-1 <sup>7</sup> / <sub>8</sub> "	6'-5 <sup>3</sup> / <sub>16</sub> "	1'-8 <sup>13</sup> / <sub>16</sub> "	4'-3 <sup>15</sup> / <sub>16</sub> "	5'-11 <sup>11</sup> / <sub>16</sub> "
4'-0"	6'-11 <sup>1</sup> / <sub>8</sub> "	8'-0"	9'-1 <sup>1</sup> / <sub>4</sub> "	4'-1 <sup>1</sup> / <sub>16</sub> "	5'-7 <sup>7</sup> / <sub>8</sub> "	7'-1 <sup>11</sup> / <sub>16</sub> "	2'-3 <sup>11</sup> / <sub>16</sub> "	4'-7 <sup>7</sup> / <sub>16</sub> "	6'-6"
4'-6"	7'-11 <sup>1</sup> / <sub>8</sub> "	8'-10 <sup>3</sup> / <sub>8</sub> "	10'-1 <sup>1</sup> / <sub>4</sub> "	4'-8 <sup>1</sup> / <sub>2</sub> "	6'-1 <sup>7</sup> / <sub>8</sub> "	7'-10 <sup>13</sup> / <sub>16</sub> "	2'-10 <sup>5</sup> / <sub>8</sub> "	4'-10 <sup>7</sup> / <sub>8</sub> "	7'-1 <sup>15</sup> / <sub>16</sub> "
5'-0"	8'-11 <sup>1</sup> / <sub>8</sub> "	9'-8 <sup>1</sup> / <sub>4</sub> "	11'-1 <sup>1</sup> / <sub>4</sub> "	5'-5 <sup>1</sup> / <sub>16</sub> "	6'-7 <sup>7</sup> / <sub>8</sub> "	8'-6 <sup>11</sup> / <sub>16</sub> "	3'-5 <sup>9</sup> / <sub>16</sub> "	5'-2 <sup>3</sup> / <sub>8</sub> "	7'-7 <sup>13</sup> / <sub>16</sub> "
5'-6"	9'-11 <sup>1</sup> / <sub>8</sub> "	10'-7 <sup>13</sup> / <sub>16</sub> "	12'-1 <sup>1</sup> / <sub>4</sub> "	6'-1 <sup>7</sup> / <sub>16</sub> "	7'-1 <sup>7</sup> / <sub>8</sub> "	9'-3 <sup>1</sup> / <sub>8</sub> "	4'-1 <sup>1</sup> / <sub>2</sub> "	5'-5 <sup>13</sup> / <sub>16</sub> "	8'-2 <sup>3</sup> / <sub>4</sub> "
6'-0"	10'-11 <sup>1</sup> / <sub>8</sub> "	11'-5 <sup>9</sup> / <sub>16</sub> "	13'-1 <sup>1</sup> / <sub>4</sub> "	6'-9 <sup>15</sup> / <sub>16</sub> "	7'-7 <sup>7</sup> / <sub>8</sub> "	9'-11 <sup>5</sup> / <sub>8</sub> "	4'-7 <sup>7</sup> / <sub>16</sub> "	5'-9 <sup>5</sup> / <sub>16</sub> "	8'-9 <sup>11</sup> / <sub>16</sub> "
6'-6"	11'-11 <sup>1</sup> / <sub>8</sub> "	12'-3 <sup>15</sup> / <sub>16</sub> "	14'-1 <sup>1</sup> / <sub>4</sub> "	7'-6 <sup>7</sup> / <sub>16</sub> "	8'-1 <sup>7</sup> / <sub>8</sub> "	10'-8 <sup>1</sup> / <sub>8</sub> "	5'-2 <sup>3</sup> / <sub>8</sub> "	6'-3 <sup>4</sup> / <sub>4</sub> "	9'-4 <sup>5</sup> / <sub>8</sub> "
7'-0"	12'-11 <sup>1</sup> / <sub>8</sub> "	13'-2 <sup>3</sup> / <sub>8</sub> "	15'-1 <sup>1</sup> / <sub>4</sub> "	8'-2 <sup>15</sup> / <sub>16</sub> "	8'-7 <sup>7</sup> / <sub>8</sub> "	11'-4 <sup>5</sup> / <sub>8</sub> "	5'-9 <sup>5</sup> / <sub>16</sub> "	6'-4 <sup>3</sup> / <sub>16</sub> "	9'-11 <sup>9</sup> / <sub>16</sub> "
7'-6"	13'-11 <sup>1</sup> / <sub>8</sub> "	14'-3 <sup>4</sup> / <sub>4</sub> "	16'-1 <sup>1</sup> / <sub>4</sub> "	8'-11 <sup>3</sup> / <sub>4</sub> "	9'-1 <sup>7</sup> / <sub>8</sub> "	12'-1 <sup>1</sup> / <sub>8</sub> "	6'-4 <sup>3</sup> / <sub>16</sub> "	6'-7 <sup>11</sup> / <sub>16</sub> "	10'-6 <sup>1</sup> / <sub>2</sub> "
8'-0"	14'-11 <sup>1</sup> / <sub>8</sub> "	14'-11 <sup>1</sup> / <sub>8</sub> "	17'-1 <sup>1</sup> / <sub>4</sub> "	9'-7 <sup>7</sup> / <sub>8</sub> "	9'-7 <sup>7</sup> / <sub>8</sub> "	12'-9 <sup>9</sup> / <sub>16</sub> "	6'-11 <sup>1</sup> / <sub>8</sub> "	6'-11 <sup>1</sup> / <sub>8</sub> "	11'-1 <sup>3</sup> / <sub>8</sub> "
8'-6"	15'-11 <sup>1</sup> / <sub>8</sub> "	15'-9 <sup>1</sup> / <sub>2</sub> "	18'-1 <sup>1</sup> / <sub>4</sub> "	10'-4 <sup>3</sup> / <sub>4</sub> "	10'-1 <sup>7</sup> / <sub>8</sub> "	13'-6 <sup>1</sup> / <sub>16</sub> "	7'-6 <sup>1</sup> / <sub>16</sub> "	7'-2 <sup>5</sup> / <sub>8</sub> "	11'-8 <sup>5</sup> / <sub>16</sub> "
9'-0"	16'-11 <sup>1</sup> / <sub>8</sub> "	16'-7 <sup>15</sup> / <sub>16</sub> "	19'-1 <sup>1</sup> / <sub>4</sub> "	11'-7 <sup>7</sup> / <sub>8</sub> "	10'-7 <sup>7</sup> / <sub>8</sub> "	14'-2 <sup>9</sup> / <sub>16</sub> "	8'-1"	7'-6 <sup>1</sup> / <sub>16</sub> "	12'-3 <sup>1</sup> / <sub>4</sub> "
9'-6"	17'-11 <sup>1</sup> / <sub>8</sub> "	17'-6 <sup>5</sup> / <sub>16</sub> "	20'-1 <sup>1</sup> / <sub>4</sub> "	11'-9 <sup>5</sup> / <sub>16</sub> "	11'-1 <sup>7</sup> / <sub>8</sub> "	14'-11 <sup>1</sup> / <sub>16</sub> "	8'-7 <sup>15</sup> / <sub>16</sub> "	7'-9 <sup>1</sup> / <sub>2</sub> "	12'-10 <sup>3</sup> / <sub>16</sub> "
10'-0"	18'-11 <sup>1</sup> / <sub>8</sub> "	18'-4 <sup>11</sup> / <sub>16</sub> "	21'-1 <sup>1</sup> / <sub>4</sub> "	12'-5 <sup>13</sup> / <sub>16</sub> "	11'-7 <sup>7</sup> / <sub>8</sub> "	15'-7 <sup>1</sup> / <sub>2</sub> "	9'-2 <sup>7</sup> / <sub>8</sub> "	8'-1"	13'-5 <sup>1</sup> / <sub>8</sub> "
10'-6"	19'-11 <sup>1</sup> / <sub>8</sub> "	19'-3 <sup>1</sup> / <sub>8</sub> "	22'-1 <sup>1</sup> / <sub>4</sub> "	13'-2 <sup>5</sup> / <sub>16</sub> "	12'-1 <sup>7</sup> / <sub>8</sub> "	16'-4"	9'-9 <sup>3</sup> / <sub>4</sub> "	8'-4 <sup>7</sup> / <sub>16</sub> "	14'-1 <sup>1</sup> / <sub>16</sub> "
11'-0"	20'-11 <sup>1</sup> / <sub>8</sub> "	20'-1 <sup>1</sup> / <sub>2</sub> "	23'-1 <sup>1</sup> / <sub>4</sub> "	13'-10 <sup>13</sup> / <sub>16</sub> "	12'-7 <sup>7</sup> / <sub>8</sub> "	17'-1 <sup>1</sup> / <sub>2</sub> "	10'-4 <sup>11</sup> / <sub>16</sub> "	8'-7 <sup>15</sup> / <sub>16</sub> "	14'-7"
11'-6"	21'-11 <sup>1</sup> / <sub>8</sub> "	20'-11 <sup>7</sup> / <sub>8</sub> "	24'-1 <sup>1</sup> / <sub>4</sub> "	14'-7 <sup>1</sup> / <sub>4</sub> "	13'-1 <sup>7</sup> / <sub>8</sub> "	17'-9"	10'-11 <sup>5</sup> / <sub>8</sub> "	8'-11 <sup>3</sup> / <sub>8</sub> "	15'-1 <sup>7</sup> / <sub>8</sub> "
12'-0"	22'-11 <sup>1</sup> / <sub>8</sub> "	21'-10 <sup>1</sup> / <sub>4</sub> "	25'-1 <sup>1</sup> / <sub>4</sub> "	15'-3 <sup>3</sup> / <sub>4</sub> "	13'-7 <sup>7</sup> / <sub>8</sub> "	18'-5 <sup>1</sup> / <sub>16</sub> "	11'-6 <sup>9</sup> / <sub>16</sub> "	9'-2 <sup>7</sup> / <sub>8</sub> "	15'-8 <sup>13</sup> / <sub>16</sub> "
12'-6"	23'-11 <sup>1</sup> / <sub>8</sub> "	22'-8 <sup>11</sup> / <sub>16</sub> "	26'-1 <sup>1</sup> / <sub>4</sub> "	16'-1 <sup>1</sup> / <sub>4</sub> "	14'-1 <sup>7</sup> / <sub>8</sub> "	19'-1 <sup>15</sup> / <sub>16</sub> "	12'-1 <sup>3</sup> / <sub>8</sub> "	9'-6 <sup>5</sup> / <sub>16</sub> "	16'-3 <sup>3</sup> / <sub>4</sub> "

# Framed Take-Up

## 2035.01687 Framed Take-Up

Factory made, ready to be hoisted and hung, this frame provides a rigid base and helps make alignment positive. The frame is permanently mounted; only the actuator and conveyor move. Tensioning is accomplished with your choice of screw, spring, or air cylinder packages listed below. Available for 2'-0" R curves (4' maximum track spread).

Some type of tensioning is necessary on all Zig-Zag conveyor systems to take up slack chain created by wear or temperature changes. In addition to the factory made versions described on this page, Richards-Wilcox makes screw take-up fittings for field assembly.

NOTE: Complete unit consists of one frame and one set of hardware for screw, spring or air take-up.

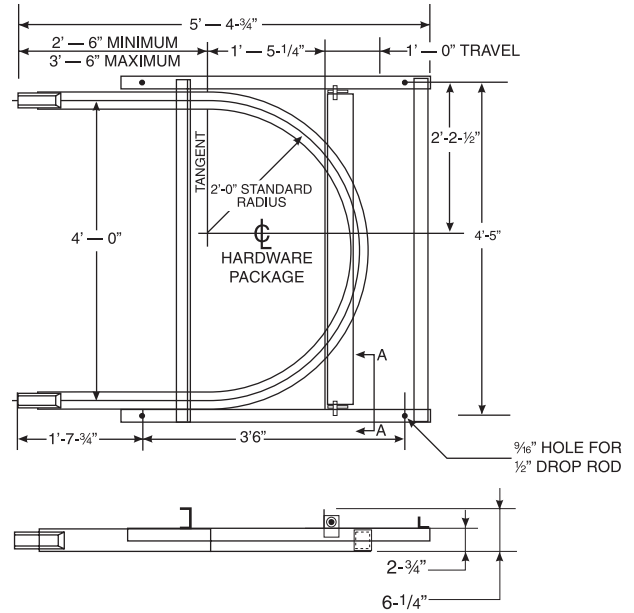

## Framed Take-Up Actuator Packages

Catalog No.	Description
2035.01700	Air Take-Up Package
2035.02685	Screw Take-Up Package
2035.02686	Spring Take-Up Package



2035.01700 Air Package



2035.02685 Screw Package



2035.02686 Spring Package

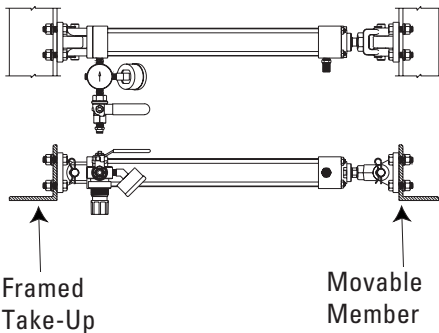

Framed Take-Up

Movable Member

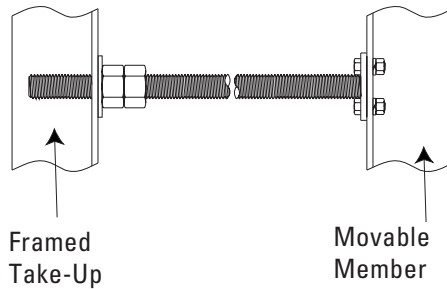

Framed Take-Up

Movable Member

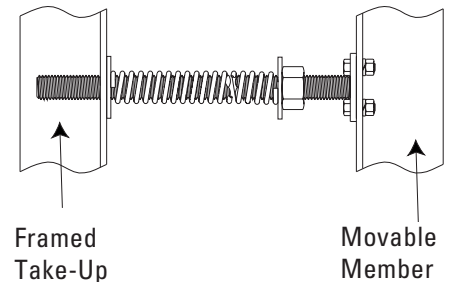

Framed Take-Up

Movable Member

# Take-Up Fittings And Expansion Sleeve

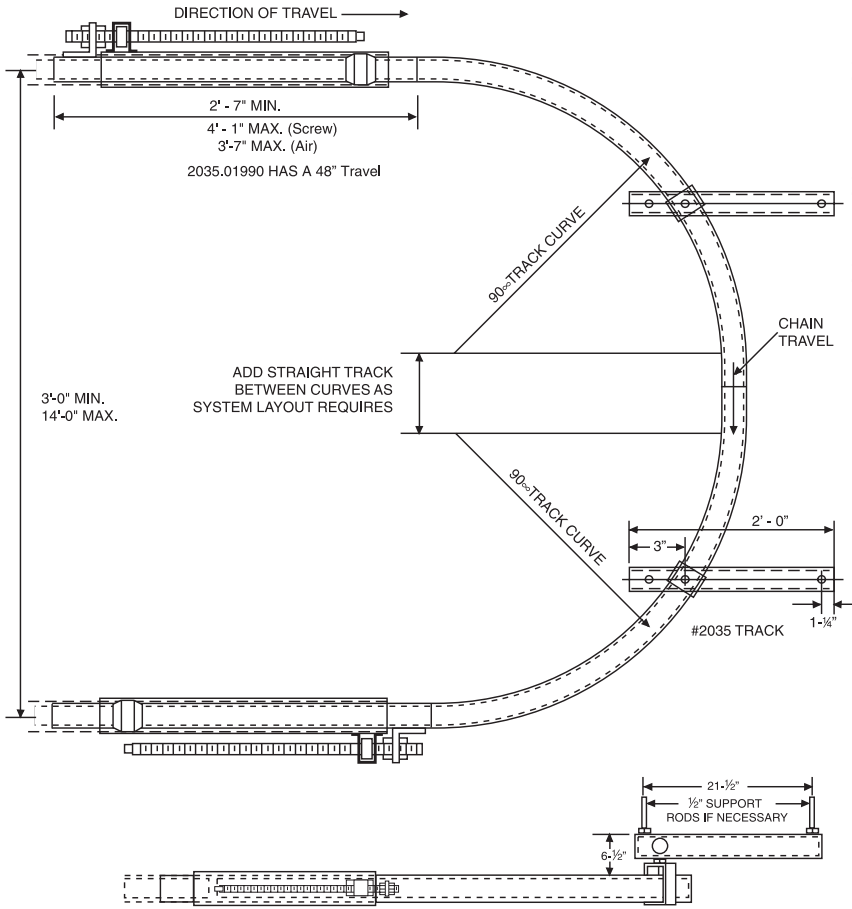

2035.00583 Screw Take-Up Fittings 1'-6" Travel (Shown)

2035.01990 Screw Take-Up Fittings 4'-0" Travel

2035.02497 Air Take-Up Fittings 1'-0" Travel

NOTE: Curves are not included in assembly.

2035.00583

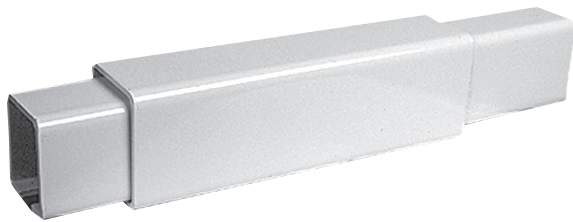

## 2035.01114 Expansion Sleeve

Expansion sleeves are used mainly in bake ovens and are located in each track in the area of the oven expansion joint. This allows both oven and conveyor to expand and contract in unison. Many ovens, depending on length and temperature, do not have expansion joints. In such cases, it is often advisable to use an expansion sleeve at the exit and entrance tracks to prevent snaking or waviness in the track both inside and outside the oven.

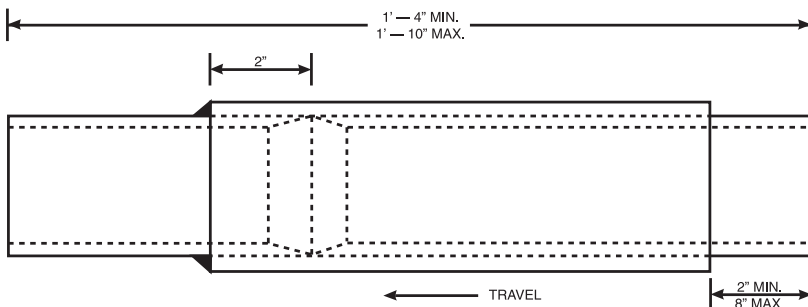

Relative to installation, the movable track in the sleeve should be moved out 2" from the compressed length which would then be an overall length of 1'-6" instead of 1'-4" as shown. This allows for both contraction and expansion in the track.

## Drive Units

The drive units are fabricated using a skeleton drive unit. The motor and reducer are connected with sprockets and roller chain to the head shaft, which drive the caterpillar chain and transmit the power to the conveyor chain. Adequate protection is provided for reasonable momentary overloads, and the assembly is also equipped with a friction clutch for protection against excessive overload.

The 2035.01371 drive uses a  $\frac{3}{4}$  horsepower inverter duty motor and a speed reducer with a 50 to 1 ratio. The drive has a constant speed of 16 feet per minute at 60 hertz, or by using the 2035.02798 (230V) or 2035.02800 (460V) A.C. inverter, has a speed range of 3 to 16 FPM.

The 2035.01372 drive uses a 1- $\frac{1}{2}$  horsepower inverter duty motor and a speed reducer with a 20 to 1 ratio. The drive has a constant speed of 45 feet per minute at 60 hertz, or by using the 2035.02799 (230V) or 2035.02802 (460V) A.C. inverter, has a speed range of 9 to 45 FPM.

These drives are used in Zig-Zag Power Chain Conveyors, Twin-Trak and Over-Way Power & Free Conveyor Systems.

The capacity is 750 lbs. Chain Pull.

NOTE: The chain covers are supplied in Safety Yellow.



Drive Unit (shown with Chain Guards)



Drive Unit (shown without Chain Guards)

## Skeleton Drive

The 2035.01373 skeleton drive unit incorporates the use of a caterpillar drive chain connection to the head shaft and idler shaft assembly. The skeleton drive is not equipped with a motor, reducer, friction clutch, driven sprocket, or roller chain.

The skeleton drive unit is used in Zig-Zag, Twin-Trak and Over-Way applications. Most commonly, the unit is used where the customer needs to replace their existing drive, but wants to use the existing motor, reducer, and sprockets. The skeleton is also used where the customer wants to supply his own motor, reducer, and sprockets. The unit can be used with an extended head shaft and jackshaft to join two or more conveyors together for timing purposes.

The capacity of the unit is 750 lbs. Chain Pull.



2035.01373 (shown with Chain Guards)

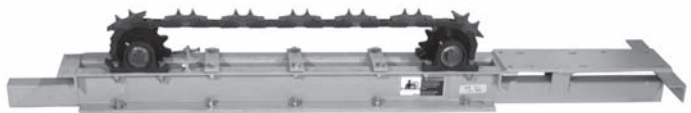

2035.01373 (shown without Chain Guards)

# Conveyor System Controls

Richards-Wilcox is your single source for hardware controls and software to make your manufacturing environment more productive. From fixed path systems with push button control to real time information processing conveyors, Richards-Wilcox ensures accurate and efficient process control for your material handling system.

## Control Options

- **Operator Interface Displays**  
Provides on-line status of system processes and direct input to critical system functions.
- **Graphical User Interface (GUI)**  
Improves operator productivity by providing on-line status of system processes and production information to maximize efficiency; exchanges information between critical system functions and the shop floor. Additional features include complete system diagnostics, alarm functions, report generation and direct communication with host computer.
- **Highly Recognized Industrial Components**  
Richards-Wilcox uses only the newest hardware platforms, open system architecture and easy-to-use software configurations.
- **All Systems Meet NEC and JIC Specifications**
- **Easy Installation, Operation and Maintenance**
- **Emergency Shutdown from Any Desired Location**

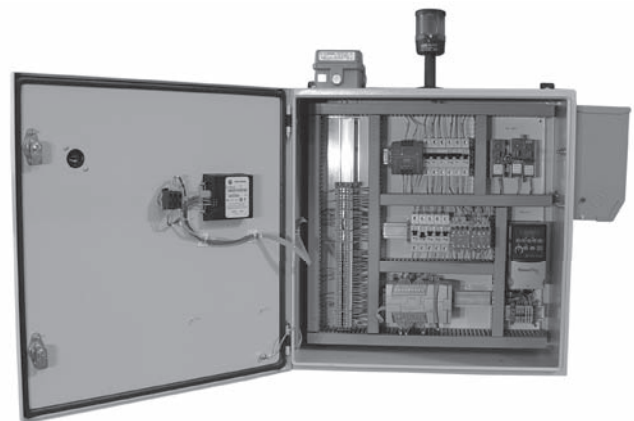

## Lubrication and Inspection Section

The proper lubrication of the conveyor chain is of paramount importance not only to the successful operation of a conveyor system, but to the life of the product as well. Proper lubricant should be recommended by a qualified lubricating engineer who has made a study of the processing machinery and atmospheric conditions to which the system will be subjected. Special safeguards must be taken to protect the chain when it moves through high temperatures, extremely low temperatures, acid conditions such as bonderizing, alkaline washers, or other chemicals which could reduce the life of the bearings and other parts. We caution against the use of graphite based lubricants which tend to build up excessive deposits of foreign matter unless the chain is thoroughly cleaned at regular intervals. We urge the use of our sanitary hook in acid or paint spray conditions.

### 2035.02893 Automatic Controlled Lubricator

This automatic timer controlled lubricator is designed to precisely lubricate the critical bearing points of the conveyor chain. It has five nozzles located to dispense lubricant on the vertical and lateral wheel bearings, vertical link pin and roller. It is equipped with a 168 hour adjustable timer which can be set for as little as 20 minutes out of 168 hours of conveyor operation.

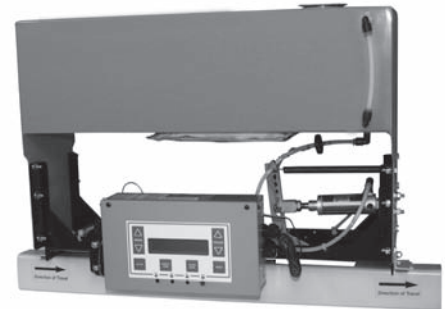

2035.02893 Automatic Timer Controlled Lubricator

### 2035.00669 Electro-Brush Oiler

The brush type oiling device makes contact with the chain, distributing the lubricant to the various parts. A 115 volt solenoid shut-off valve is provided at the bottom of the tank reservoir.



2035.00669 Electro-Brush Oiler

### 2035.00664 Brush Oiler (Not Shown)

The brush oiler applies lubrication to the chain by gravity feed. The brush makes contact with the chain, distributing the lubricant to the various parts. A toggle shut off at the top of the reservoir is provided. NOTE: We do not recommend this oiler in finishing systems.

### 2035.00820 Inspection Track Section

The inspection track section formed out of  $\frac{3}{16}$ " track facilitates inspection and maintenance at points other than the drive unit. It may be placed in any run of straight track. This section is made with the top and sides open down to the center of the chain. This allows for full inspection of the chain for proper lubrication, chain tension, and general condition of the conveyor chain. The opening is covered by a removable housing equipped with a handle. The inspection section also permits easy installation and removal of chain. The most desirable location is at the lowest point between the output of the drive unit and the take-up unit. The inspection section is furnished in a standard finish to match the rest of the system.

The inspection section is used in all Zig-Zag, Twin-Trak, and Over-Way systems. In certain applications, such as a large system, it may be desirable to use several inspection sections.



2035.00820 Inspection Section

# 2035 Standard Load Pendants

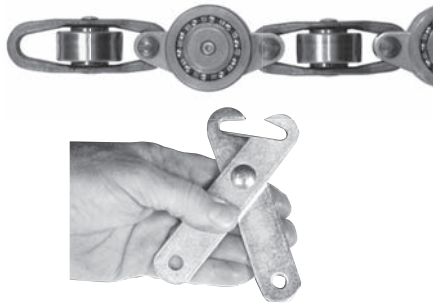

2035.00319 Standard Clevis Load Pendants, Capacity 75 lbs.

We have developed a series of standard load carrying devices designed to cover the essential requirements for connecting the load to the conveyor chain.

Since the ultimate device required to carry the load on the conveyor must be specially designed to fit the article which is being handled, it is almost impossible to illustrate a load pendant for every application. It is also desirable in many cases to experiment with various types of load carriers before finding the one most satisfactory for the job.

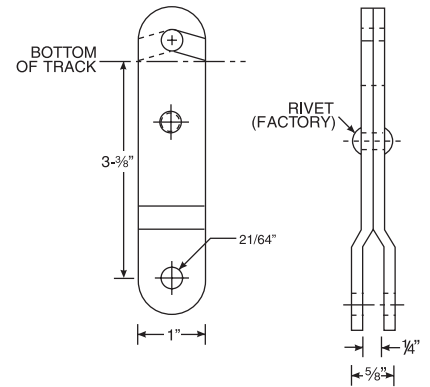

2035.00319

The standard load pendants shown on this and following pages are carried in stock for immediate shipment.

Almost any type of load suspension fitting can be attached to the 2035.00319 clevis pendant.

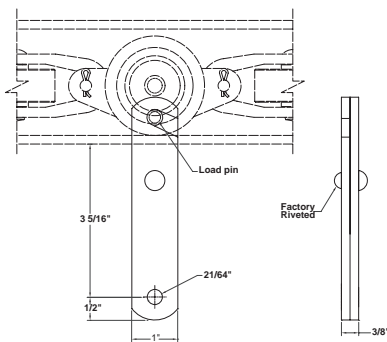

2035.00318

## Straight Side Pendant

The Straight Side Pendant is similar to the Standard Clevis Pendant except the pendant sides are straight. It uses a scissor-like action to attach directly to the load pin on the vertical link of the conveyor chain.

The pendant may be spaced on multiples of 6". The pendant is furnished in a zinc-plated finish. This type of pendant is used where it is permitted to have swinging loads. The pendant is allowed to pivot, as the conveyor makes elevation changes.

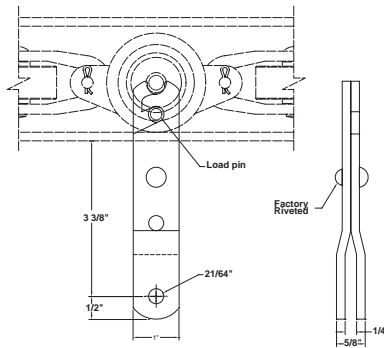

2035.00316

## Rigid Clevis Pendant

The Rigid Clevis Pendant is designed to be used where a swinging load may be objectionable. This pendant is similar to the Rigid Straight Side Pendant except there is an offset in the pendant sides to allow for a 1/4" gap.

The pendant may be spaced on multiples of 6". The pendant is furnished in a zinc-plated finish. This pendant always remains perpendicular to the track. The pendant can be attached to a load bar or directly to a product rack.

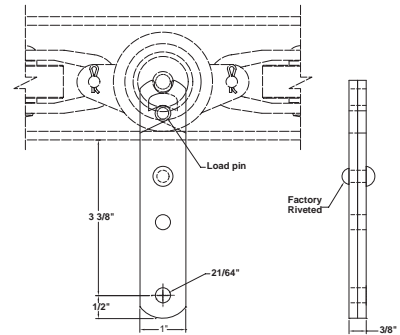

2035.00317

## Rigid Straight Side Pendant

The Rigid Straight Side Pendant is similar to the Rigid Clevis Pendant except the sides are straight. It may be spaced on multiples of 6". It attaches directly to the load pin on the vertical link of the conveyor chain and is furnished in a zinc-plated finish.

This pendant may be used where a swinging load may be objectionable or not permitted. The pendant always remains perpendicular to the track.

## 2035 Standard Load Pendants

### 2035.00264 Rigid "V" Pendant Capacity 75 lbs. Max.

Standard offset of 8" as shown may be increased on special order to 11" maximum for vertical travel or any desired offset for horizontal travel, and decreased to a minimum of 3-<sup>1</sup>/<sub>4</sub>".



2035.00264  
Rigid "V" Pendant

### 2035.02706 Suspension Indexing Load Hook Capacity 75 lbs.

The load hook illustrated is used to carry loads that must be indexed from time to time by the operator at 90°. Bottom of track to throat of hook 7-<sup>3</sup>/<sub>8</sub>".



2035.02706  
Suspension Indexing Load Hook

### 2035.02775 Swivel Fixture Capacity 75 lbs. Max.\*

This fixture permits continuous rotation of a product through a finishing operation by permitting the ball-bearing roller to turn against a continuous flat bearing strip through the turning area.



2035.02775  
Swivel Fixture

### 2035.02693 Single Suspension Indexing Load Hook Capacity 75 lbs.

The pendant is a two piece design with the rigid pendant and cast hook assembly. The pendant may be spaced on multiples of 6". This pendant is used in Zig-Zag applications where the load must be manually or automatically indexed in 90° increments.



2035.02693  
Single Suspension  
Indexing Load Hook

### 2035.00257 Double Suspension Load Hook Capacity 150 lbs.

The load is suspended from two vertical load units increasing the capacity of the load carrier. Standard clevis pendants are attached to the conveyor chain on 6" centers. The load hook revolves freely.

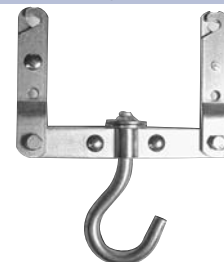

2035.00257  
Double Suspension Load Hook

*\*Where unit loads are less than 8 lbs. minimum preloading is recommended to insure smooth rotation.*



## 2035 Standard Load Pendants



2035.02772  
Double Suspension  
Load Bar Assembly

### 2035.02772 Double Suspension Load Bar Assembly

#### Capacity 150 lbs. per Assembly

By suspending the load from two points on the chain, the load carrying capacity is increased. This pendant can be attached to the conveyor chain on a minimum of 12" centers. The basic load bar assembly provides a means of attaching a product hook or clevis directly to the center hole.



2035.02702  
Double Suspension  
Load Hook Assembly

### 2035.02702 Double Suspension Load Hook Assembly

#### Capacity 150 lbs. per Assembly

By suspending the load from two points on the chain, the load carrying capacity is increased. This pendant can be attached to the conveyor chain on a minimum of 12" centers. The Load Hook assembly is used for finishing applications where the load must be manually indexed in 90° increments.



2035.02699  
Double Suspension Rotating  
Star Indexing Pendant

### 2035.02699 Double Suspension Rotating Star Indexing Pendant

#### Capacity 150 lbs. for Manual Indexing

Distance from bottom of track to throat of hook is 8-<sup>7</sup>/<sub>8</sub>". This pendant can be used to manually index or automatically index the part. This pendant can be used with a Rotating Cam or Continuous Rotating Cam, permitting automatic rotation and indexing in increments of 90°. The pendants and load bar have a zinc plated finish while the hook assembly is finished in Richards-Wilcox Gloss-Tek powder coat. This pendant is most commonly used for finishing applications where it is necessary to rotate the part. This pendant assembly can be spaced on 6" increments with a minimum of 12" centers.

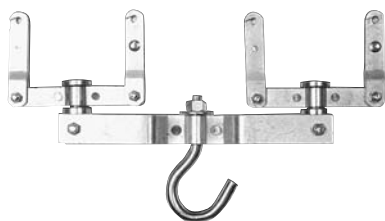

2035.00430  
Multiple Suspension  
Load Hook Capacity

### 2035.00430 Multiple Suspension Load Hook

#### Capacity 300 lbs.

By suspending the load from four points on the chain, the load carrying capacity is increased again. Standard clevis pendants are attached at four points to each vertical link pendant, and the load bar is free to swivel so that there will be no binding action when going around curves. Bottom of track to throat of hook is 9-<sup>1</sup>/<sub>16</sub>".

## Zig-Zag Stainless Steel and Unpainted Parts

Richards-Wilcox offers many of our standard conveyor components in 304 Stainless Steel for use in harsh environments. Below is a listing of the commonly available stainless steel conveyor parts. Other conveyor parts are available in stainless steel upon request.

### Stainless Steel

ITEM NUMBER	DESCRIPTION
2035.02119	S.S. TRACK 7ga 5'-0" LENGTH
2035.01964	S.S. TRACK 11ga 8'-0" LENGTH
2035.01912A	S.S. BRACKET PROPER
2035.00820SS	S.S. INSPECTION SECTION 7ga
2035.02725	S.S. HORIZ CURVE 18" R x 90 DEG 7ga
2035.01352SS	S.S. HORIZ CURVE 2'-0" R x 90 DEG 7ga
2035.01338SS	S.S. HORIZ CURVE 3'-0" R x 90 DEG 7ga
2035.02118	S.S. TOP VERT CURVE 2'-0" R x 90 DEG 7ga
2035.02131	S.S. TOP VERT CURVE 2'-0" R x 45 DEG 7ga
2035.02133	S.S. TOP VERT CURVE 2'-0" R x 30 DEG 7ga
2035.02117	S.S. BOT VERT CURVE 2'-0" R x 90 DEG 7ga
2035.0213	S.S. BOT VERT CURVE 2'-0" R x 45 DEG 7ga
2035.02132	S.S. BOT VERT CURVE 2'-0" R x 30 DEG 7ga
2035.00583SS	S.S. SCREW TAKE-UP w/ TRACK (18" travel)

Richards-Wilcox also offers many of our standard conveyor components in an unpainted form for use in curing ovens or OEM applications where welding and/or special finishes are to be applied. Below is a listing of the commonly available unpainted conveyor parts. Other conveyor parts are available unpainted upon request.

### Unpainted

ITEM NUMBER	DESCRIPTION
2035.00471A	UNP. TRACK 7ga 10'-0" LG W/O HOLE
2035.00021A	UNP. JOINT BRACKET
2035.01912U	UNP. PLAIN TRACK BRACKET
2035.02064A	UNP. HORIZ CURVE 1'-6" R X 90 DEG (Hard)
2035.01352A	UNP. HORIZ CURVE 2'-0" R X 90 DEG (Hard)
2035.01338A	UNP. HORIZ CURVE 3'-0" R X 90 DEG
2035.01344A	UNP. HORIZ CURVE 4'-0" R X 90 DEG
2035.00705A	UNP. CARRIER INSERT SECTION
2035.00820A	UNP. INSPECTION SECTION
2035.01114U	UNP. EXPANSION SLEEVE
2035.00980A	UNP. TOP VERT CURVE 2'-0" R x 90 DEG (Hard)
2035.02757U	UNP. TOP VERT CURVE 2'-0" R x 45 DEG (Hard)
2035.02756A	UNP. TOP VERT CURVE 2'-0" R x 30 DEG (Hard)
2035.00981A	UNP. BOT VERT CURVE 2'-0" R x 90 DEG (Hard)
2035.02759U	UNP. BOT VERT CURVE 2'-0" R x 45 DEG (Hard)
2035.02758A	UNP. BOT VERT CURVE 2'-0" R x 30 DEG (Hard)
2035.00583U	UNP. SCREW TAKE-UP (18" Travel)
2035.01687A	UNP. FRAMED TAKE-UP BASIC ASSEMBLY (12" travel)

# Organizer Loop

The Organizer Loop is a gravity loop conveyor consisting of standard Richards-Wilcox materials. Ideal for any assembly application.

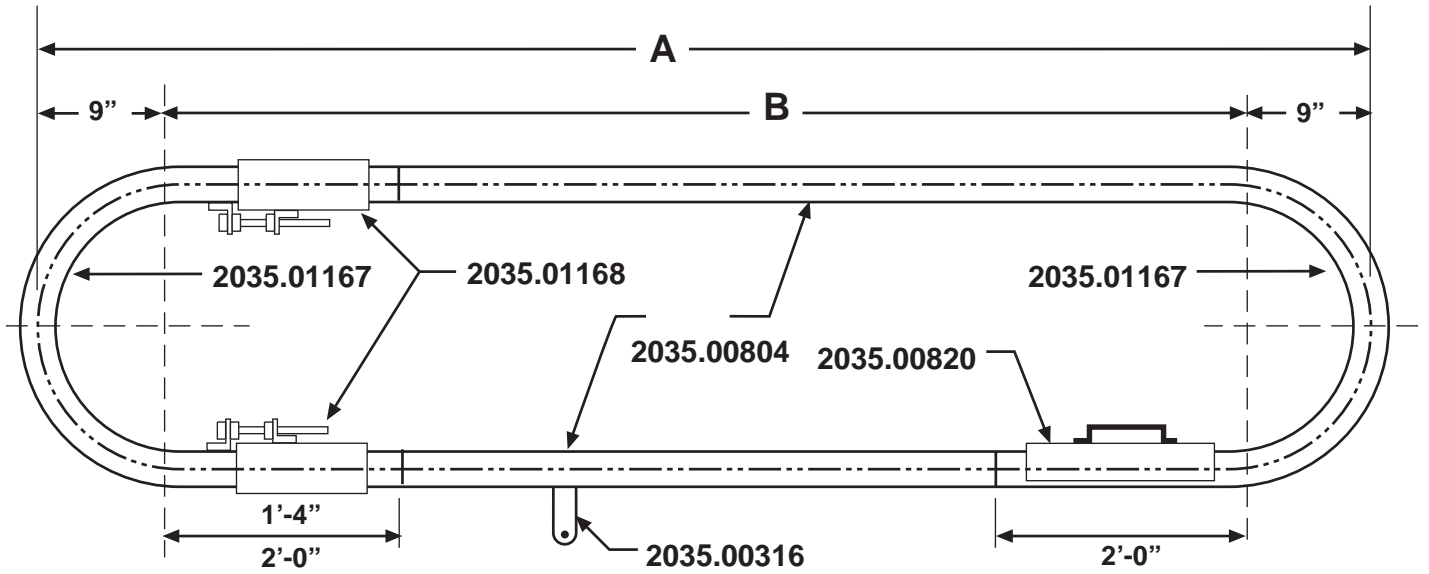

A DIM.	B DIM.	2035.00804 TRACK		2035.00155	2035.00820	2035.01167	2035.01168	2035.01974 CHAIN	
		QUANTITY REQUIRED	ORDER QUANTITY	WELDING JIG	INSPECTION SECTION	CURVE	TAKEUPS	QUANTITY REQUIRED	ORDER QUANTITY
8'-0"	6'-6"	10 ft.	(10 ft.)	(1)	1	2	2	18 ft.	(20 ft.)
10'-0"	8'-6"	14 ft.	(20 ft.)	(1)	1	2	2	22 ft.	(30 ft.)
12'-0"	10'-6"	18 ft.	(20 ft.)	(1)	1	2	2	26 ft.	(30 ft.)
14'-0"	12'-6"	22 ft.	(30 ft.)	(1)	1	2	2	30 ft.	(30 ft.)
16'-0"	14'-6"	26 ft.	(30 ft.)	(1)	1	2	2	34 ft.	(40 ft.)
18'-0"	16'-6"	30 ft.	(30 ft.)	(1)	1	2	2	38 ft.	(40 ft.)
20'-0"	18'-6"	40 ft.	(40 ft.)	(1)	1	2	2	42 ft.	(50 ft.)
24'-0"	22'-6"	42 ft.	(50 ft.)	(1)	1	2	2	50 ft.	(50 ft.)
30'-0"	28'-6"	54 ft.	(60 ft.)	(1)	1	2	2	62 ft.	(70 ft.)
35'-0"	33'-6"	64 ft.	(70 ft.)	(1)	1	2	2	72 ft.	(80 ft.)
40'-0"	38'-6"	74 ft.	(80 ft.)	(1)	1	2	2	82 ft.	(90 ft.)

NOTE 1: It will be necessary to add the cost of the 2035.00316 rigid pendants when using Richards-Wilcox Conveyor Chain.

# Powered Organizer Loop

The Powered Organizer Loop is a conveyor that incorporates the over and under design of the standard gravity Organizer Loop with the benefit of a drive unit driving the chain. Customers are not limited to the straight conveyor, but should contact Richards-Wilcox to design a layout. The layout shown below illustrates the minimum material needed for a Powered Organizer Loop

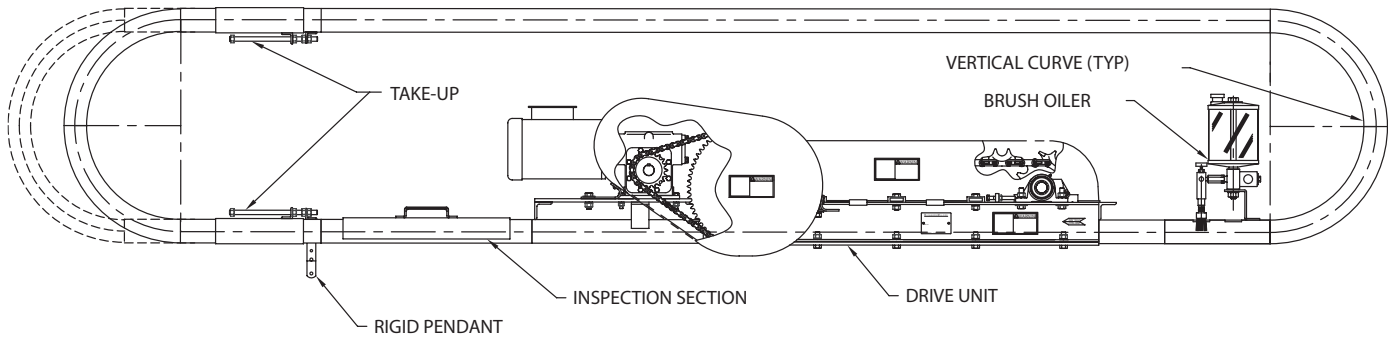

Note 1: Richards-Wilcox recommends using 12" radius vertical curves when an Organizer Loop is powered. Part number is 2035.03021.

# Suggested Suspension Methods

## Welded

Where the building trusses are too far apart for the 10'-0" hanger supports, it is necessary to install headers or a superstructure. Since conditions vary greatly from job to job, the header steel must be designed and installed to accommodate the conveyor and the building.

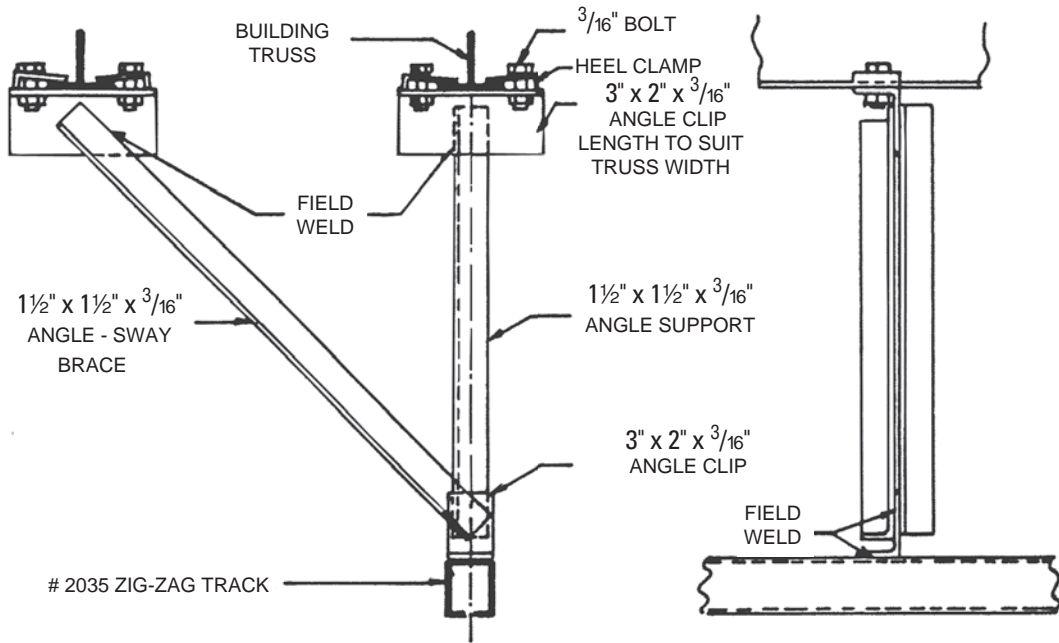

### BOLTED CONSTRUCTION

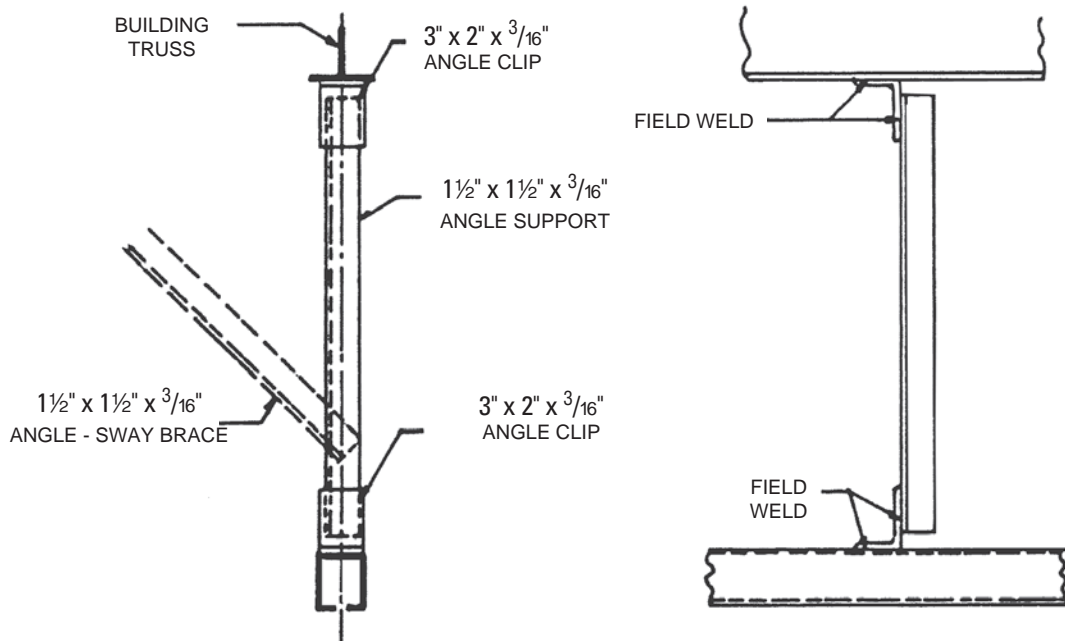

### WELDED CONSTRUCTION

# Suggested Suspension Methods

## Threaded Rod

Connection to Lower Chord of Building Truss or Joist with Rod Type Hangers

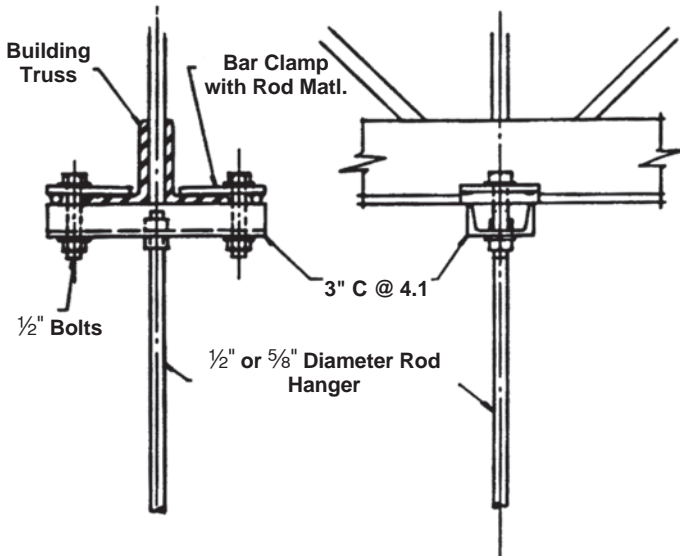

Connection to Channel Header with Rod Type Hangers

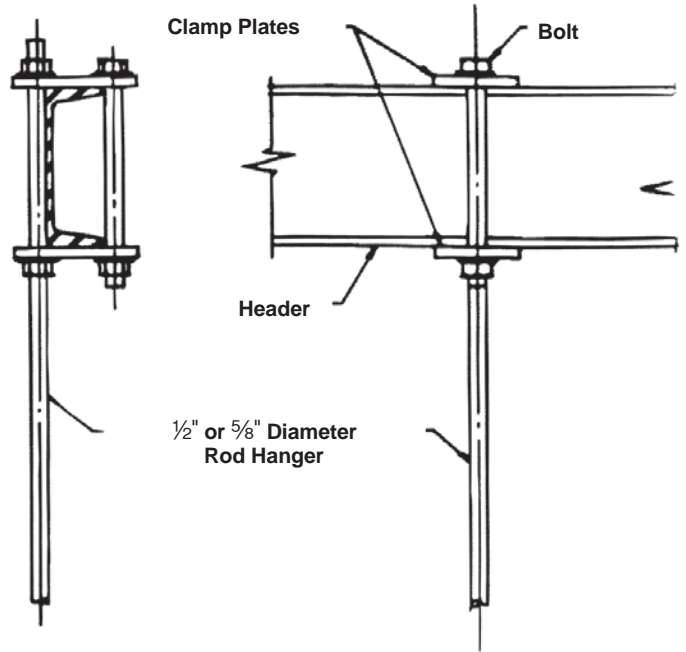

Connection to 2035 Track Using Welded Bracket and Rod Type Hanger

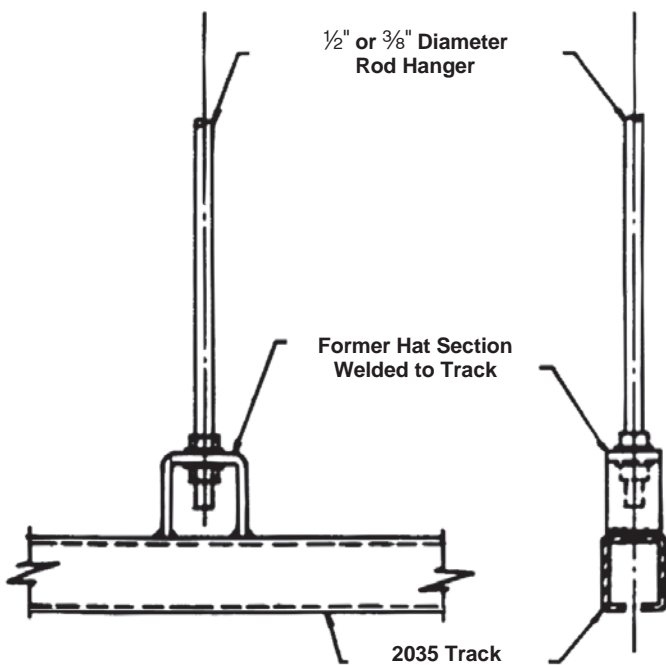

Connection to 2035 Track Using 2035.01912 Bracket

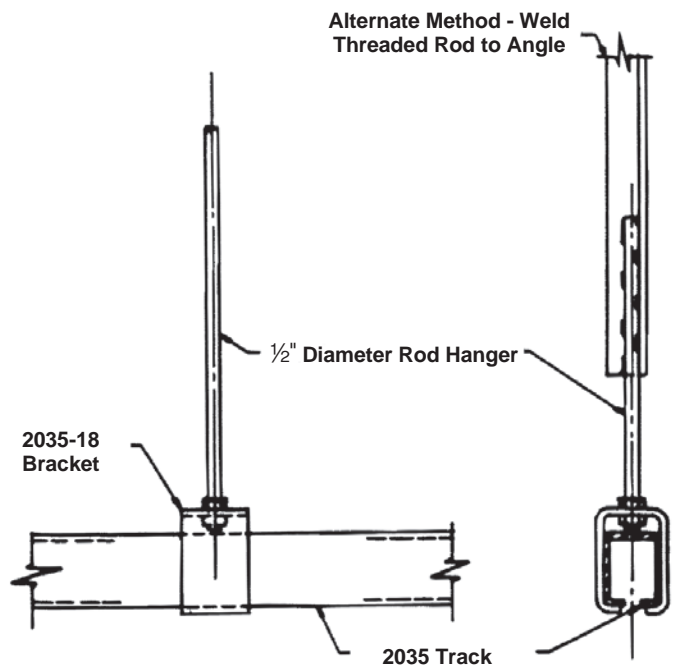

# Zig-Zag Layout

## NO. 2035 Zig-Zag Conveyors

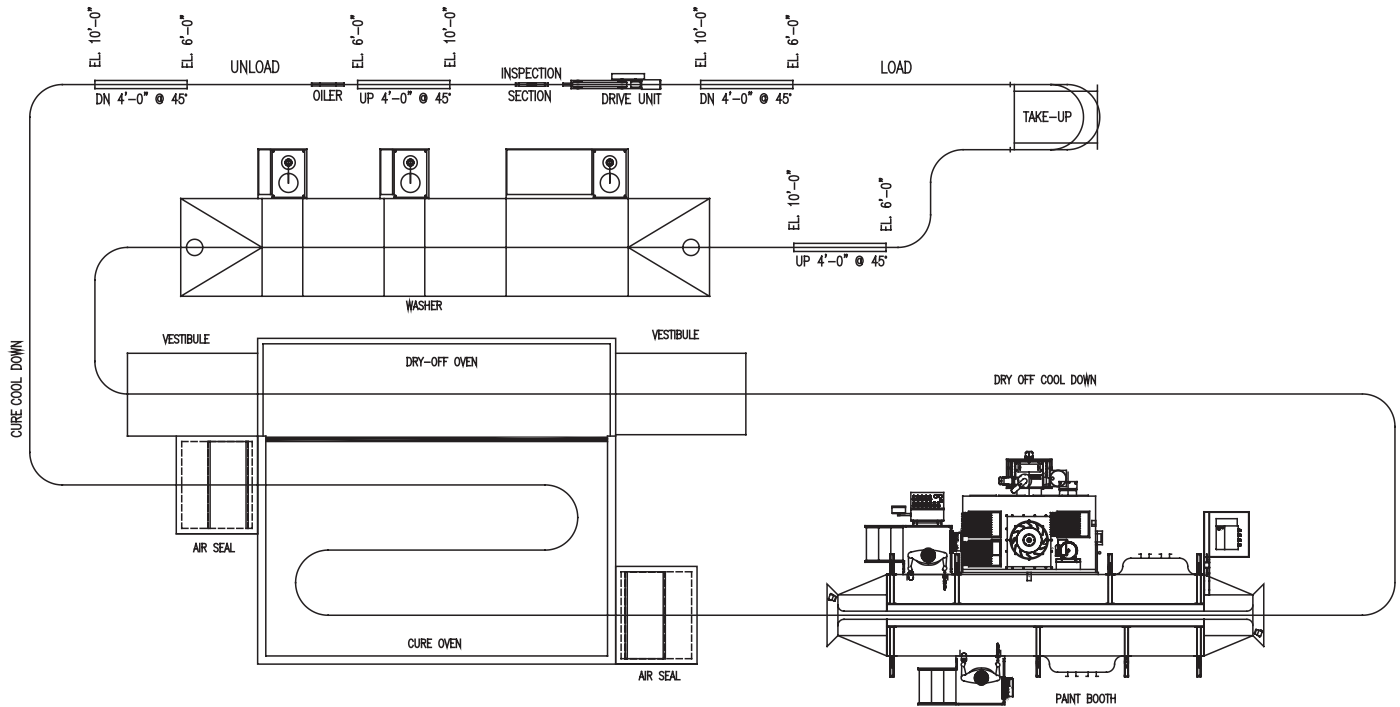

### Bill Of Material

QUANTITY	ITEM NUMBER	DESCRIPTION
3	2035.00155	Welding Jig
235	2035.02775	Swivel Fixture
37	2035.00471	Track (3/16") 10' length
1	2035.00820	Inspection Section
2	2035.00980	Top Vertical Curve 2'-0" Radius x 90 Degrees
2	2035.00981	Bottom Vertical Curve 2'-0" Radius x 90 Degrees
12	2035.01352	Horizontal Curve 2'-0" Radius x 90 Degrees
1	2035.01371	Drive Unit 3-16 FPM
1	2035.01687	Framed Take-up Package
1	2035.01700	Air Take-up Package
47	2035.01974E	Conveyor Chain 10' Lg. Cotter
2	2035.02012	Traction Wheel 24" Dia.
2	2035.02064	Horizontal Curve 1'-6" Radius x 90 Hardened
1	2035.02893	Chain Lubricator with Timer
1	2035.02728.01	Standard Control Panel







# Inverted Zig-Zag®

Inverted Zig-Zag (sometimes called "Paint-Line") uses the same track as Zig-Zag, but is inverted so the channel is facing up. This provides a barrier to prevent chain lubrication or debris from the track coming in contact with the part below.

Uniquely designed pendants and hooks enable the product to be navigated up and down inclines and declines as well as through process equipment.

Although it carries the nickname Paint-Line for its widespread use in finishing, Richards-Wilcox Inverted Zig-Zag is also used in tote/box delivery systems, order fulfillment, and distribution centers to prevent contamination of merchandise carried below the conveyor.

## Inverted Zig-Zag

Richards-Wilcox Inverted Zig-Zag Conveyor Systems combine reliable, clean conveyor operation with the vertical flexibility made possible only through the unique design of Richards-Wilcox Inverted Pendants.

Unlike a rigid pendant, the investment cast Inverted Pendant pivots forward and backward on the wheel axle to allow free rotation up to 30° with no torque or wear on the chain assembly. The Inverted Conveyor system is ideal in production environments where clean operation is essential.

Inverted Zig-Zag is supplied with a one-piece removable pendant for easy maintenance, replacement, and configuration.

Because of its design the need for drip pans is eliminated.

Inverted Zig-Zag uses standard Zig-Zag chain and track with slightly modified drives, curves, inspection sections, pendants, lubricators, and take-ups to allow for inverted operation.

### Typical Inverted Applications

- Paint and Varnish Applications
- Electronics Manufacturing
- Pin Systems
- Pan Conveyors
- Kitting and Assembly
- Tote Conveyors
- Package Handling
- Empty Carton
- Trash Removal



# Inverted Pendants



2035.02817 Inverted Hook Assembly

## 2035.02817 Inverted Hook Assembly

- 25 lb. load capacity
- Designed to keep carrier plumb when loaded
- Easier to attach and remove from inverted pendant
- No tools needed



2035.02818 Inverted Hook Assembly

## 2035.02818 Inverted Hook Assembly

- 75 lb. load capacity
- Designed to keep carrier plumb when loaded
- Easier to attach and remove from inverted pendant
- No tools needed



2035.02091 Inverted Pendant

## 2035.02091 Inverted Pendant

- 30° Free Rotation on inclines and declines
- No excessive wear and torque to chain like other inverted pendants
- Easy to remove for reconfiguration
- C-hook mounts easily — no tools

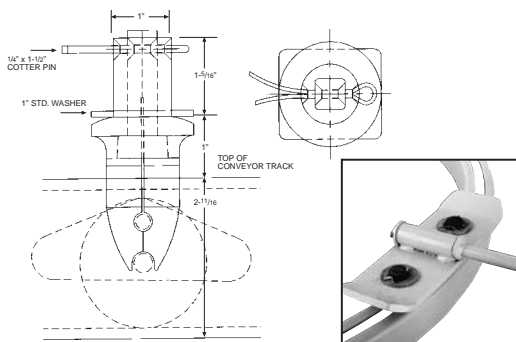

2035.01220 Inverted Pendant

## 2035.01220 Inverted Pendant

- 45° Free Rotation on inclines and declines
- 150 lb. Capacity (when used with inverted shoe pictured at left)
- More resistant to wear from torsional loading
- Consult Customer Service for shoe pictured at left

# Inverted Inspection and Drive Unit

## 2035.02334 Inverted Inspection Section

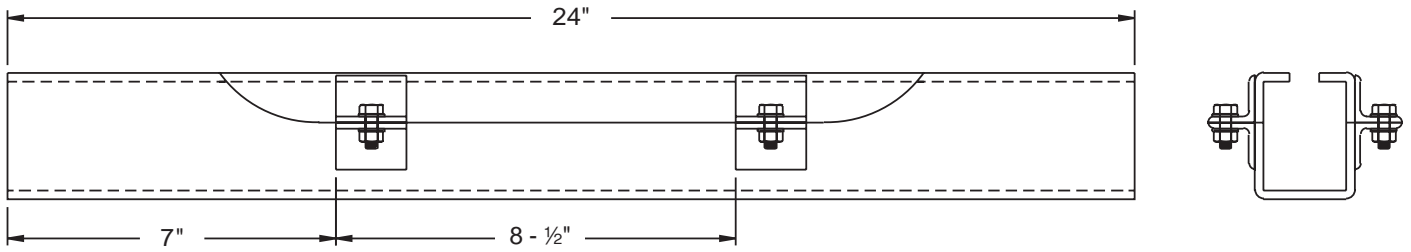

## Inverted Drive Unit

2035.02815 — 16 fpm  
2035.02816 — 45 fpm

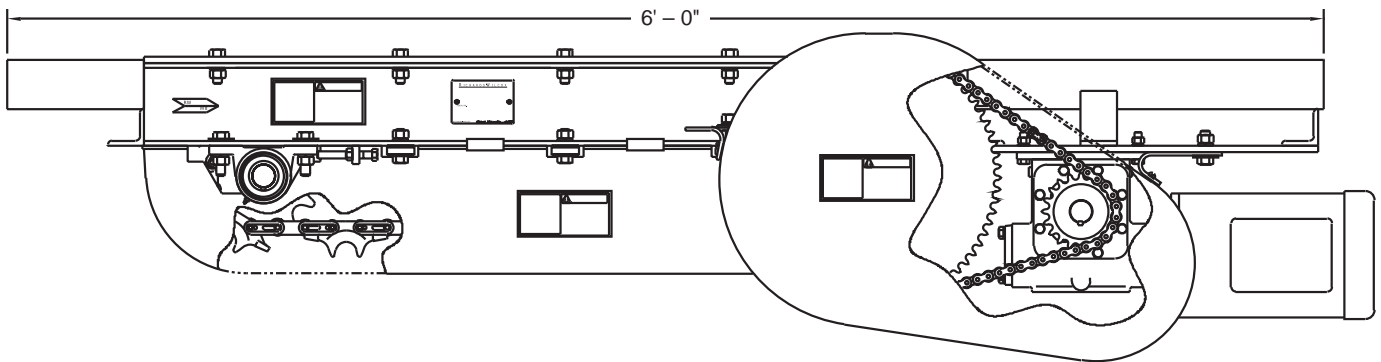
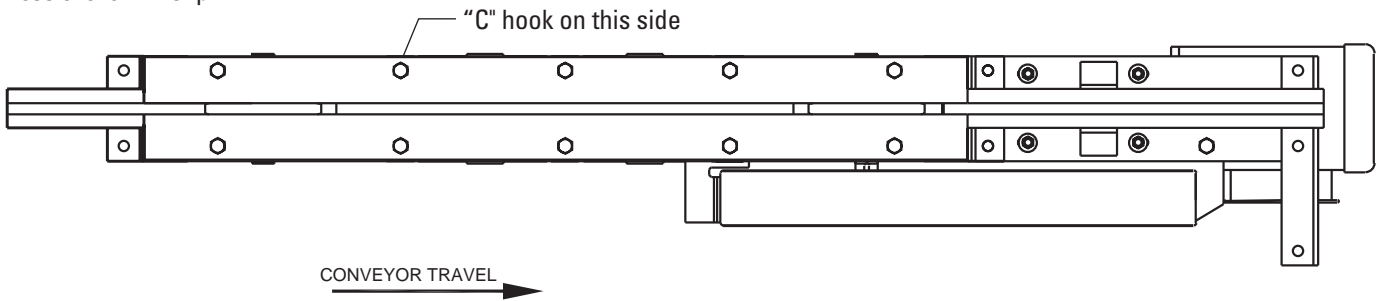

# Inverted Zig-Zag Take-Up

2035.02128 Inverted Screw Take-Up Package (1'-6" Travel)

2035.02328 Inverted Air Take-Up Package (Not Shown) (1'-0" Travel)

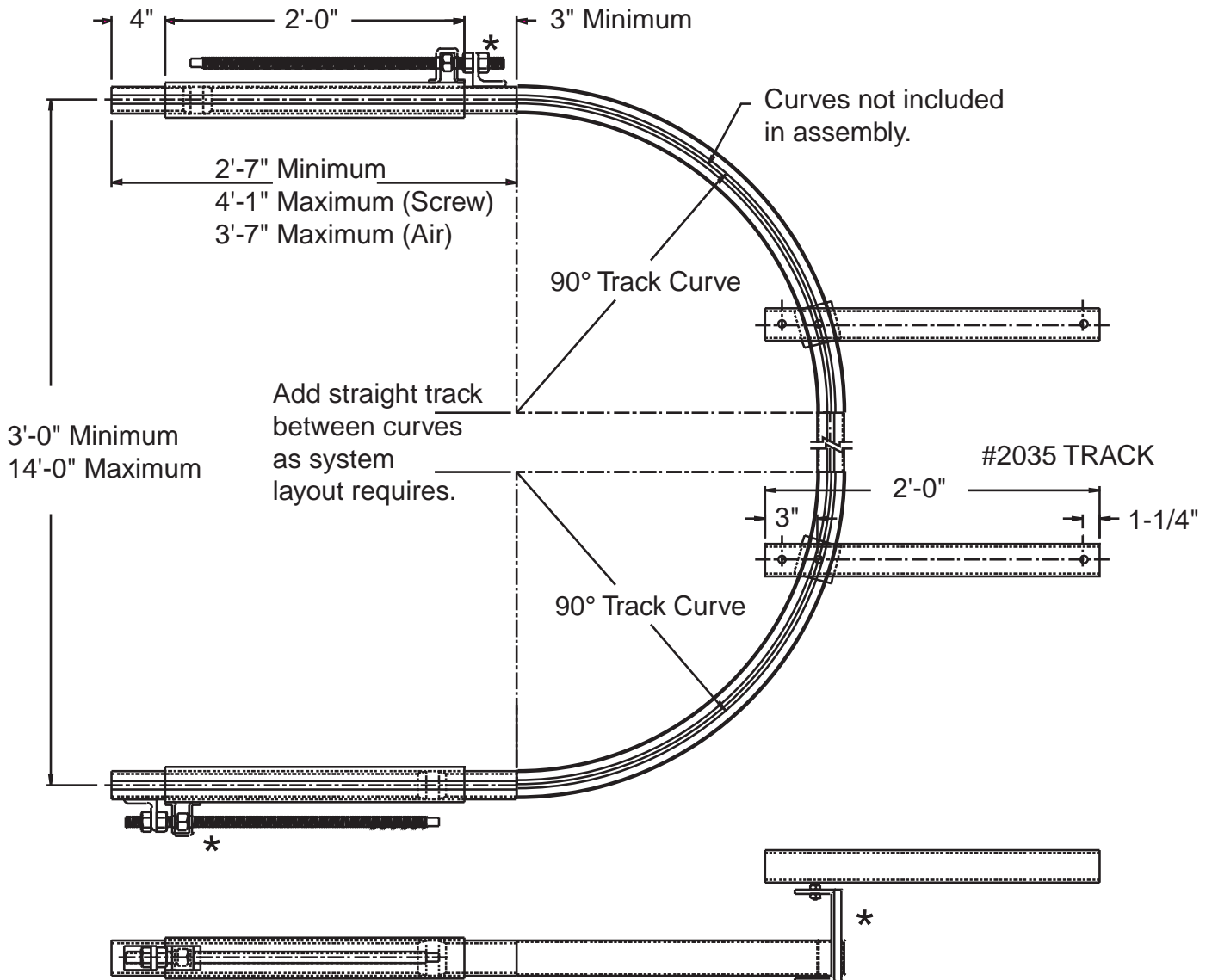

2035.02128 Inverted Screw Take-up Package

Note: Parts marked \* must be installed on opposite side of the "C" hooks.





# Zig - Zag<sup>®</sup>

## *BOLT-TOGETHER*

In systems that require non-welded installation applications Zig-Zag Bolt-Together is a good solution that provides the same capacity and components as Zig-Zag or Zig-Zag Inverted.

Standard components come with end yokes that align and bolt for easy assembly and disassembly for maintenance.

## Zig-Zag Bolt-Together

Richards-Wilcox Bolt-Together Zig-Zag Conveyor is designed for easy installation without welding. Using track components from either Zig-Zag or Inverted Zig-Zag ensures all the benefits derived from both product lines.

Standard components including track, curves, take-ups, inspection sections, drive units, and lubricators are built with end yokes. The yokes align the ends of the conveyor components for positive alignment allowing carriers or chain a smooth running surface. All Safe-Rail carriers, conveyor chain, and pendants or hooks can be used to transport product. Capacities do not change with Bolt-Together systems.

### Typical Applications for Bolt-Together

- Empty Box Delivery
- Textile
- All systems that do not allow welding

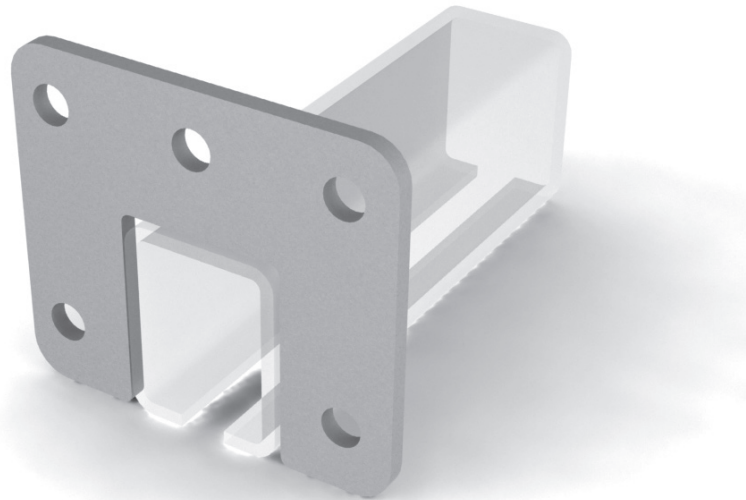
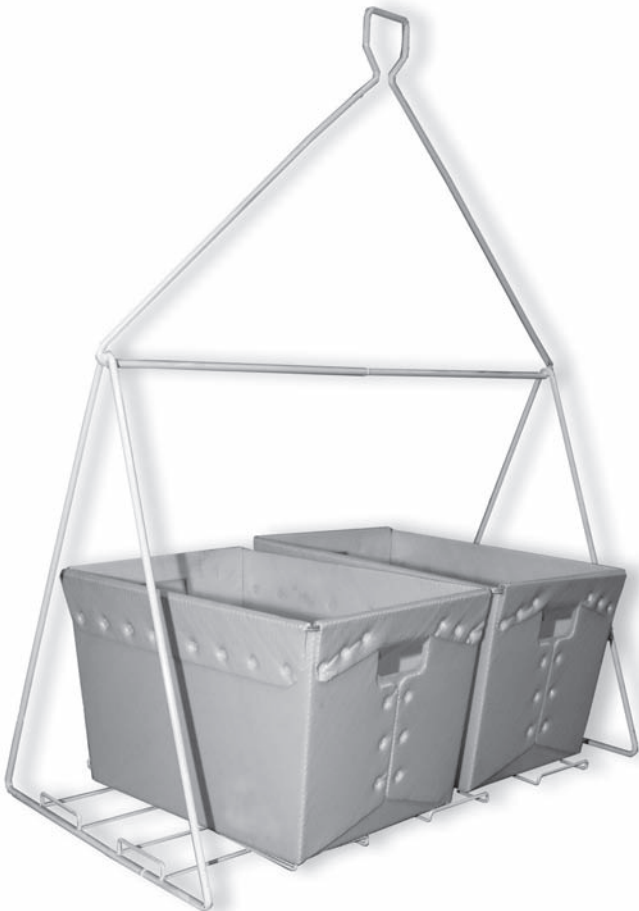
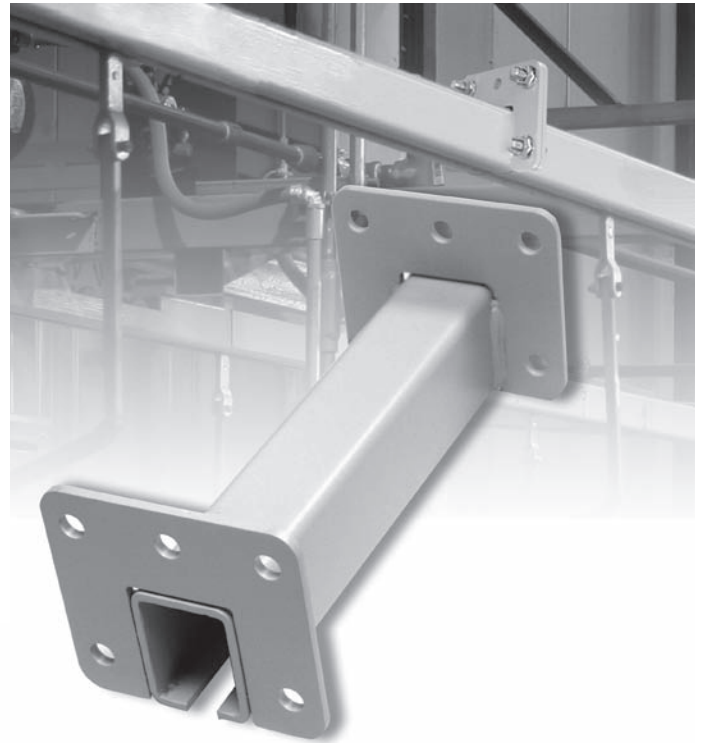



# Track Connection and Support for Bolt-Together

Bolt-Together Zig-Zag Track uses yokes that align and connect with nuts and bolts (not supplied).

Like most conveyor systems, Bolt-Together Zig-Zag systems usually have a cutoff run of track that is non-standard in length. In order to complete the run, Track Yokes, Bolt-on Yokes and Clamp Bracket Assemblies may be required.

## Track Yoke

Track yokes are used in the field when it is necessary to fabricate a special length section of Bolt-Together Track using a cut off portion of a standard Bolt-Together part for extra hanging points. This Track Yoke must be field welded to the track.

## Bolt On Yoke

The Bolt On Yoke is used when a non-standard length of track is needed to finish a system. When a length of track is cut to the length needed it leaves only one factory welded yoke on the track. The Bolt On Yoke is slid on the cut end and the wedges are pulled together by means of the bolts through the sides of the bracket. When these wedges tighten, they securely clamp the yoke allowing the odd length to be bolted to the system using the yokes.

## Support Bracket Assembly

The clamp style support bracket is specially designed for Bolt Together allowing brackets to be installed around standard track sections. The bracket comes in two pieces that bolt together to sandwich the track section between the yokes. See the Bracket Spacing chart below for spacing according to load.

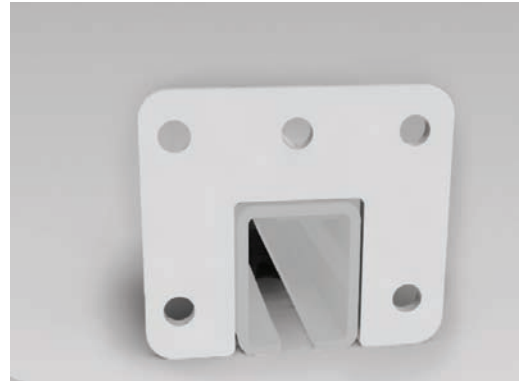

Track Yoke – 2045.00009



Bolt On Yoke – 2045.00029

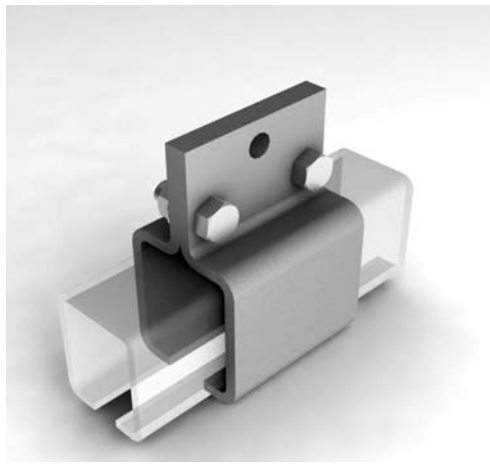

Support Bracket Assembly – 2045.00031

## Bracket Spacing According To Load

Single Carriers – Distance Between Supports				
Load in LBS.	125	250	500	1000
2045.00001	10'-0"	10'-0"	10'-0"	8'-0"

Continuous Loading – Pounds per Foot					
Load in LBS.	125	150	200	250	300
2045.00001	10'-0"	8'-0"	7'-0"	6'-0"	5'-0"

# Drive Unit and Inspection Section Zig-Zag Bolt-Together

## Bolt Together Drive Unit

2045.00016 – 3/4 H.P.

2045.00017 – 1 1/2 H.P.

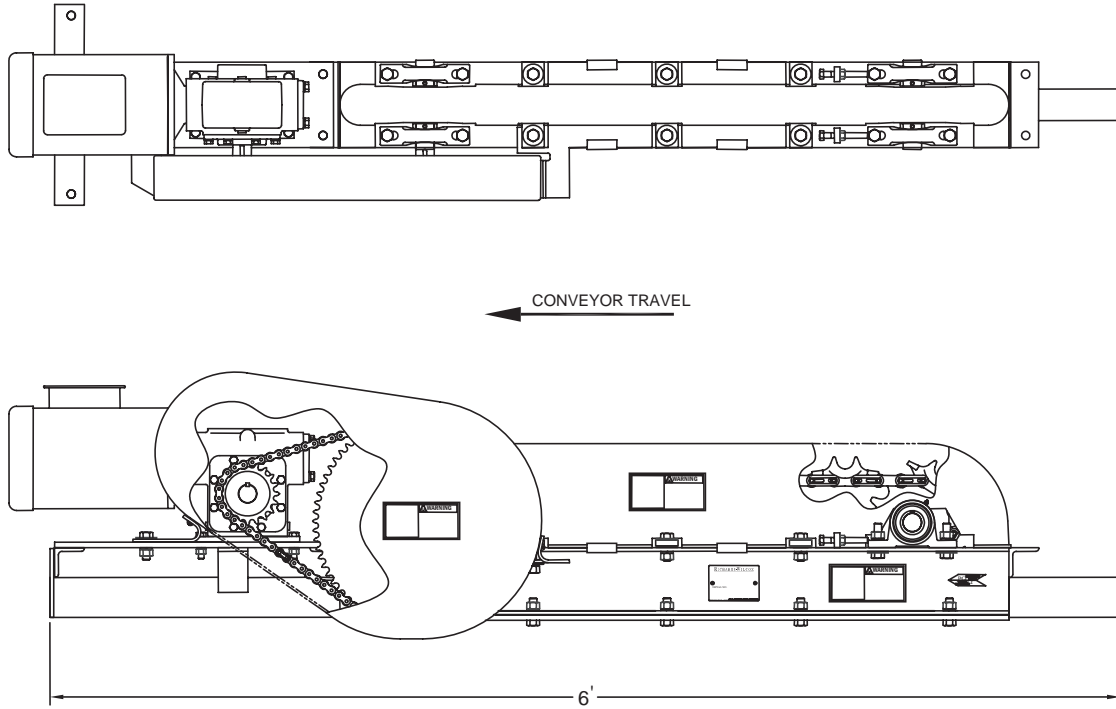

## Bolt Together Inspection Section

2045.00011

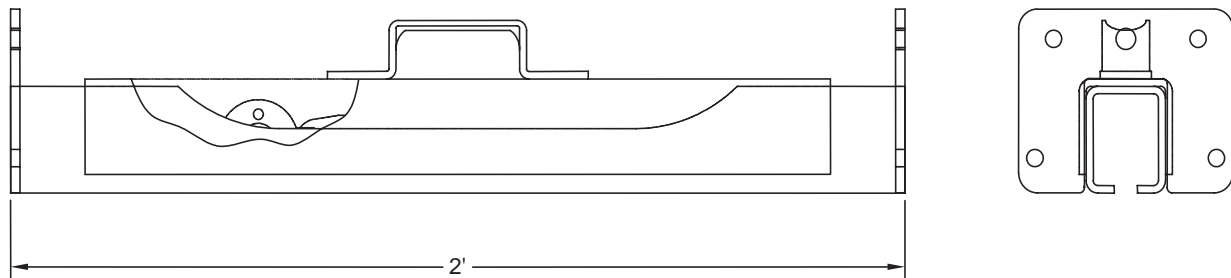

# Framed Take-Up Zig-Zag Bolt-Together

## Bolt Together Take-Up

Framed Take-Up - 2045.00022 (12" of travel)

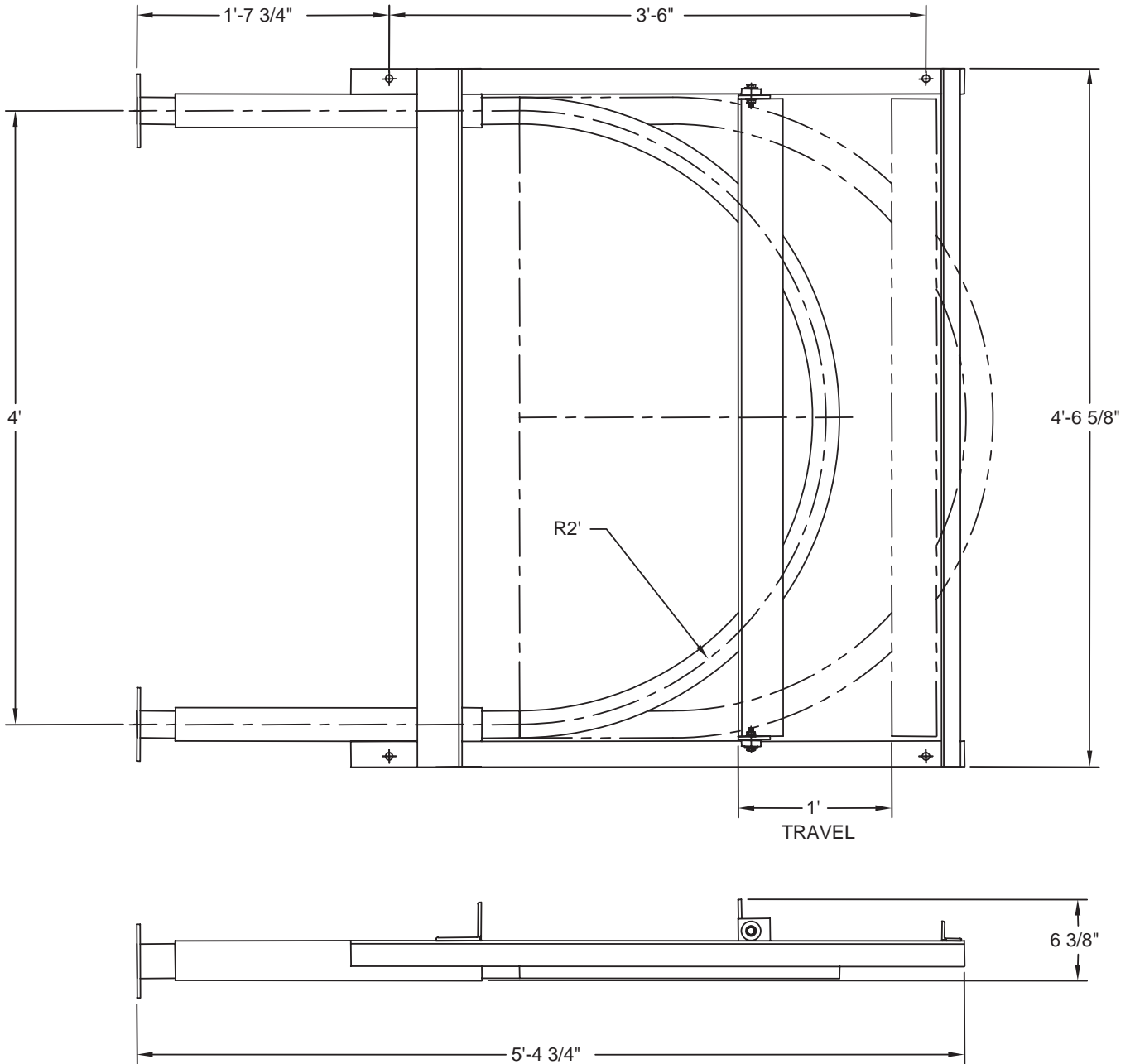

NOTE: Bolt Together Framed Take-Up uses any adjustment package also used for standard frame take-ups.

# Take-Up Fittings Zig-Zag Bolt Together

## Bolt Together Screw Take-Up Fittings

2045.00020 (18" of Travel)

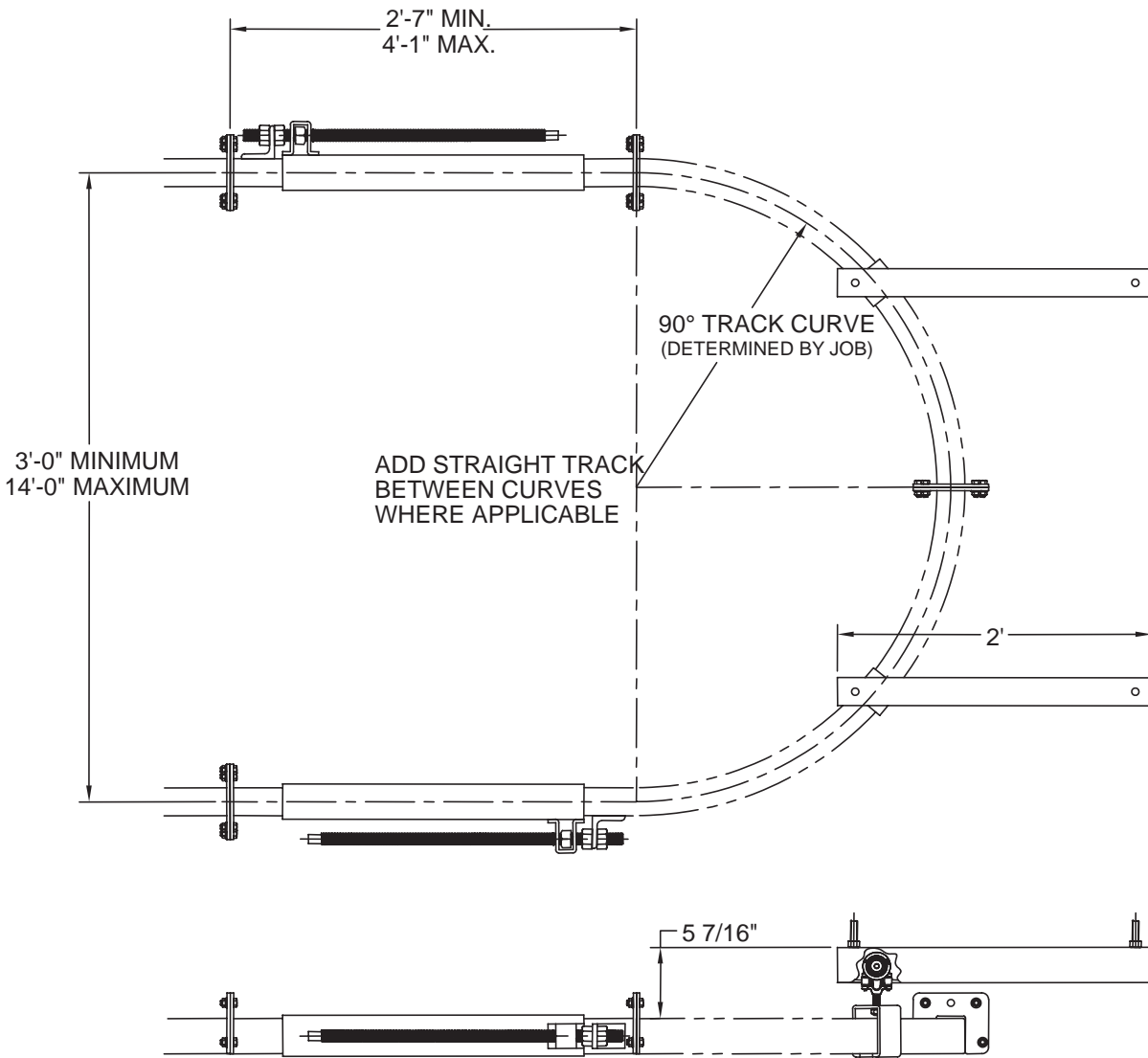

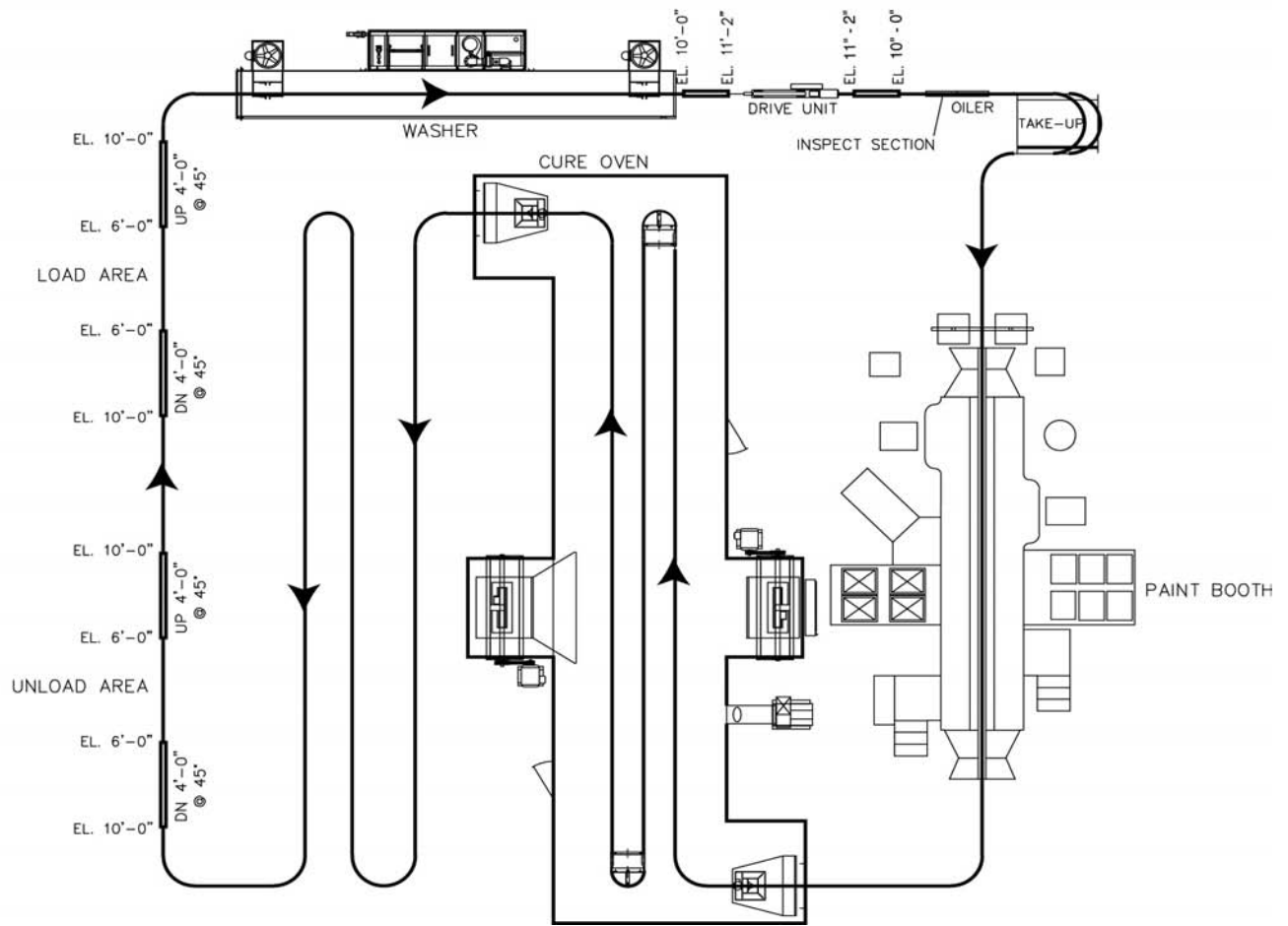

# Designing a Conveyor

# Designing a Conveyor

## STEP #1 - ASSEMBLE JOB INFORMATION

Conveyor job information is essential before continuing your conveyor design. The following are steps to assist in assembling job information.

- 1) **Conveyor Function** – Determine the function of the conveyor in relation to its purpose. What equipment is in the system such as washers, spray booths, ovens, etc.
- 2) **Plant Layout** – Draw or obtain a layout of the plant area where the conveyor is to be installed.
- 3) **Process Equipment** - Using the plant layout, locate all load areas, unload areas, and processing stations. Create a conveyor path which connects these areas following a determined sequence of operation.
- 4) **Product to be Carried** – Identify size and weight of product to be transported. In reference to the identified load, design a carrier that allows easy loading and unloading. The carrier must be designed within the maximum load rating. Also note if carriers may need to carry more than one part or product.
- 5) **Temperatures** – What temperatures will the conveyor be subject to? Maximum temperature for Richards-Wilcox conveyors is 450°F.
- 6) **Power** – Electrical characteristics need to be identified.
- 7) **Elevations** – Determine elevations of the conveyor track. Track elevations are measured from the floor line to the top of the track. The track elevation at the load and unload areas should allow a worker easy interface with the carrier. Elevations over aisles and work areas should allow a minimum of 6'-8" clearance from the floor line to the lowest obstruction hanging from the conveyor.

## STEP #2 – CONVEYOR COMPONENT DATA

In step number 2, it is important to become familiar with the standard components, their applications, and limitations.

- 1) **Track** – Straight track is offered in either 7GA. or 11GA. Most powered conveyors use 7GA. track, part number 2035.00471. Track is stocked in 10 foot lengths only and comes standard with a pebble tan powder coat finish. For high moisture or corrosive applications, track is offered in stainless steel.
- 2) **Welding Jig** – Most all conveyor systems are erected by welding the joints. The welding jig, part number 2035.00155, is installed at the open end of the track. It serves both purposes of aligning the two ends to be welded when adjusted and it prevents weld flash from extending past the inner track walls. The welding jig may be reused, but it is recommended that one welding jig be supplied for every 120 feet of conveyor.
- 3) **Inspection Section** – An inspection section, part number 2035.00820, is essential in any powered Zig-Zag system. It offers a place to inspect the conveyor chain and to remove slack chain. The inspection section that is used for inverted Zig-Zag is 2035.02334.
- 4) **Expansion Sleeve** – In systems where temperature extremes are encountered and no provision is made to accommodate expansion and contraction, an expansion sleeve should be considered. The part number is 2035.01114. For example in ovens with an expansion joint at the mid-point, an expansion sleeve should be installed in each conveyor track in line with the oven expansion joint. However, uni-construction ovens do not have expansion joints; therefore, the expansion sleeve is not necessary.
- 5) **Curves** – All changes in direction of the track, either horizontal or vertical, must be made with a curved section. Stock curves are made in 30, 45, and 90 degree turns; however, any degree can be accomplished by field cutting stock curves. There are two main principals to consider when selecting curves: product clearance and chain pull. Clearance between adjacent carriers

will determine the minimum turns needed. The recommended minimum radius for horizontal curves in a powered Zig-Zag system is 2' -0" R. Additionally, for increased conveyor life, use the largest radius possible. Vertical curves used for elevation changes should consider the slightest angle to help minimize the lift load, and prohibit interference between adjacent carriers.

- 6) **Drive Unit** – A wide variety of drive units are offered from factory stock to accommodate almost any system. The designed conveyor speed will determine the horse power of the motor. Conveyors running below 21 feet per minute will use a 3/4 horse power motor while systems between 21 and 58 feet per minute will need a 1-1/2 horse power unit. All stock drives use motors wound for 230/460 volts, 60 hertz 3 phase and are all inverter duty. If other electrical characteristics are needed, drive units are available on special order.
- 7) **Take-Up** – One take-up is required for each drive unit on a system. Take-ups consist of two adjustable sleeves, separate or supported in a frame unit, that provide an easy method of keeping slack chain at a minimum. Chain develops slack as a result of normal wear in joints. The slack chain is first apparent at the exit or downstream side of the drive unit. It is advantageous to place the take-up just downstream from the drive at a lower elevation than the drive. In no case should a take-up be located just before a drive. Two types of take-ups are automatic and manual screw. Automatic take-ups are controlled by either spring tension or air cylinders. Systems where operating temperatures are extreme or access to adjustment is not convenient would be advised to use automatic take-ups.
- 8) **Chain** – Conveyor chain is the major item in a system. The maximum operating temperature is 450°F with maximum chain pull capacity of 750 lbs. It has a maximum load capacity of 75 lbs per load point, and has a 6" pitch. Every effort must be made to stay within these operating parameters to allow maximum life of the chain. Chain is sold in either 10 foot lengths, part number 2035.01974HP, or 300 feet in a crate, part number 2035.01974.300HP.
- 9) **Lubricator** – Proper lubrication greatly extends the useful life of the conveyor chain. Consequently, automatic lubricators are strongly recommended. Although brush lubricators may be sufficient for very small transport only systems, the automatic lubricator applies lubricant directly into the important lube points on the chain in a set cycle that is dependent on the application. The lubricator should be located based on maintenance ease and to allow lubricant proper time to penetrate lube points.
- 10) **Lubricant** – The proper lubricant is governed by the conveyor application. Attention must be given toward temperature and the general operating environment. Ordinary petroleum derivatives can be harmful to chain wheel bearings. When exposed to high temperature it will leave a carbon residue on the bearing. The best lubricant in all applications should have a penetrant to carry the lubricant to the important lube points. Lubricants containing silicone should never be used with finishing systems.
- 11) **Chain Load Pendants** – The catalog shows an assortment of chain load pendants. The capacities are given for each pendant design. A single pendant can be attached to the chain on 6 inch centers. Each pendant attachment point allows a capacity of 75 lbs. Double suspension pendant assemblies allow for 150 pound carriers; and multi suspension pendants which are four point attachments, allow 300 lbs. Pendant spacing is usually dependent on load clearance through curves and product spacing to accomplish desired products per hour. This is discussed in Step #3 – System Design.

### STEP #3 – SYSTEM DESIGN

The following defines general principles used in designing a Richards-Wilcox Zig-Zag conveyor system.

- 1) **Conveyor Path** – Design a conveyor route so that all loading and unloading areas as well as any process equipment are served by the conveyor. Typical process equipment includes washers, paint booths, ovens, etc. Be sure the conveyor path does not interfere with any machines or work areas.
- 2) **Design Carrier** – The system design starts with a carrier to support the product from the conveyor. The type of carrier is influenced not only by the product to be carried, but consideration toward any process equipment the product passes through. Additionally, the carrier must be able to connect to a chain attachment, i.e. pendant.

- 3) **Track Elevations** – Once the carrier design is complete, the conveyor height can be determined at the load and unload points. Additionally, track elevation can be finalized over aisle ways and other non-related work stations. An acceptable clearance from the floor line to the bottom of the guarding is 6' -8" feet; however, industrial truck traffic must be able to pass freely where applicable.
- 4) **Carrier Spacing** – The spacing of carriers can be on a minimum of 6" or a spacing of any multiple of 6". The end user normally prefers minimum load centers for full utilization of the equipment. Load centers need to also consider clearance of adjacent carriers on incline runs and horizontal turns as they negotiate those turns. Once minimum spacing is determined for clearance, the number of carriers per minute will be the final step for carrier spacing.
- 5) **Determine Chain Pull** – Chain pull is the effort necessary to maintain the normal operating speed of a conveyor under a rated capacity load. To arrive at this figure, it is necessary to add the lift load and the friction factors, expressed as a small percentage of the live load, which acts as resistance to the progress of the conveyor. Frictional resistance is found in the bearings of the chain wheels, curves, and the drive unit itself. The percentages used for frictional resistance are for average conveyors that travel under normal conditions. When adverse environmental conditions exist or the conveyor is abnormally long and complex and exceeds the chain pull capacity of one drive, a progressive chain pull computation is necessary. Contact a Richards-Wilcox, Inc. representative if this applies.

### Short Cut Method of Chain Pull Calculation

Using a 2½% friction factor for the short cut method will cover most conditions. If there are a large number of vertical and horizontal curves, the friction factor will be slightly higher.

**Caution:** If calculated chain pull using this short cut method is in excess of 550 pounds per drive, consult Richards-Wilcox to calculate the chain pull using the long point to point accumulation method.

- 1) Determine total number of carriers in the system. The total is equal to the total conveyor length divided by the carrier spacing.
- 2) Determine number of loaded and unloaded carriers. Take the distance from loading to unloading area and divide this distance by the carrier spacing to determine the number of loaded carriers.
- 3) Determine the live load. The live load on a conveyor is equal to the sum of the weights of the chain, pendants, product carrier, and the product (load) itself.
  - a. Weight of chain equals 3.2 lbs times total feet of chain.
  - b. Weight of pendants equals total number of pendants times weight per pendant. Consult Richards-Wilcox for weights.
  - c. Weight of carriers equals total number of carriers (total length of chain divided by carrier spacing) times weight of single product carrier.
  - d. Weight of product equals number of loaded carriers (result of Step 2) times product weight.
  - e. Total of a, b, c, d equals Total Live Load on the conveyor system.
- 4) **Determine lift load.** The lift load is the amount of force required to pull the live load upward along the vertical curves in the entire system. To calculate this force, determine the difference in elevation of all the vertical curves traveling upward in the system. The net vertical rise (in feet) will be considered in the total lifting height of the conveyor.

The lift load for the elevation changes of the conveyor is computed by first taking the total lifting height (in feet) multiplied by the individual product weight (in lbs), then divided by the load spacing centers in feet. That result is then multiplied by a percentage depending on the degree of the elevation changes.

The following are percentages of the most common degree of elevation change.

- Elevation Change at 15 Degrees – 25.9%
- Elevation Change at 30 Degrees – 50%
- Elevation Change at 45 Degrees – 70.7%
- Elevation Change at 60 Degrees – 86.6%



- 5) **Determine Chain Pull.** The final step is to take the total live load from Step 3, multiply that sum by the selected friction factor of 2 ½% (0.025), and finally add the total lift load from Step 4. The result is the Total Chain Pull.
- 6) **Locate Drive and Determine Size** – First and foremost the drive must pull, not push the load. The drive should apply a pulling force on the most heavily loaded area of the system. For best results, the drive should be at the highest level of the conveyor with a take-up just after the drive in the direction of travel, preferable at a lower elevation.

Drives are sized based on the desired speed of the conveyor. All systems are designed for a chain pull at or below 750 lbs. The two most common drive units are assembled with either a 3/4 H.P. or 1-1/2 H.P. motor. Any conveyor system designed for a speed of 20 feet per minute or slower will use a 3/4 H.P. unit; and systems up to 58 feet per minute will use a 1-1/2 H.P. unit.

#### STEP #4 – INSTALLATION AND SUMMARY

The following defines general principles used in designing a Richards-Wilcox Zig-Zag conveyor system.

- 1) **Installation** – Richards-Wilcox enclosed track conveyors are designed to be erected by bolted construction or by welded construction. A small section in this guide illustrates various methods and components used to install Zig-Zag conveyors. Adverse conditions can dictate a particular installation method and the use of specific components. It is recommended that you contact Richards-Wilcox for installation services.
- 2) **Summary** – For quick and easy reference make a legend of the layout covering system design parameters. They are as follows:
  - a. Speed of Conveyor and Direction of Travel
  - b. Length of Conveyor
  - c. Carrier Spacing
  - d. Weight of Carrier
  - e. Weight of Load
  - f. Size of Load
  - g. Electrical Specifications
  - h. Legend Defining Symbols and Labels

The design procedure outlined above assumes stable environmental conditions. Conditions such as temperatures above 450°F, conveyor speed of 60 feet per minute or above, sand blast areas, or adverse atmospheric conditions preclude effective use of this design procedure. You may contact Richards-Wilcox at any time to assist with designing a system for your needs. Please refer to the following page for a Conveyor Job Information form for reference when beginning your conveyor system design.

# Conveyor Job Information

Date Received: \_\_\_\_\_ Salesman: \_\_\_\_\_

Bid Due Date: \_\_\_\_\_ Priority Number: \_\_\_\_\_

---

---

**Customer:** \_\_\_\_\_ **Contact:** \_\_\_\_\_

**End User:** \_\_\_\_\_ **Contact:** \_\_\_\_\_

**Size and Weight of Product:** H: \_\_\_\_\_ x W: \_\_\_\_\_ x L: \_\_\_\_\_  
Weight: \_\_\_\_\_ lbs Load + Rack

**Carrier Information:** \_\_\_\_\_

**Temperatures the Conveyor must Accommodate?** \_\_\_\_\_

**Installation Required?** \_\_\_\_\_ **Floor/Ceiling Supported?** \_\_\_\_\_

**Height of Conveyor (Elevation)?** \_\_\_\_\_ **Bottom of Building Steel?** \_\_\_\_\_

- If ceiling support please include: Joist Centers? \_\_\_\_\_  
Which way do they run? \_\_\_\_\_

## Controls Required?

- Process Rate and Design Speed? \_\_\_\_\_
- Operator Interface Required (ie. PanelView)? \_\_\_\_\_
- If applicable, explain interfacing with other machinery: \_\_\_\_\_

---

---

**Installation Start Date:** \_\_\_\_\_ **Completion Date:** \_\_\_\_\_

---

---

**Sequence of Operation:** (brief explanation) \_\_\_\_\_

---

---

**Notes:** (special requirements, elect. requirements, etc.) \_\_\_\_\_

## 2 Year Warranty

### RICHARDS-WILCOX STANDARD WARRANTY & LIMITATION OF LIABILITY

Richards-Wilcox Inc. warrants to Purchaser that the material and workmanship of its equipment is of good quality and free of defects. Richards-Wilcox agrees to furnish the Purchaser, without charge, F.O.B. Richards-Wilcox plant Aurora, Illinois a replacement part for any part or parts of the equipment proving defective in either material or workmanship within a period of two (2) years from the date of shipment.

THIS WARRANTY SHALL NOT BE IN FORCE AND EFFECT UNLESS: Purchaser gives Richards-Wilcox immediate notice of defective part or parts; purchaser affords Richards-Wilcox the opportunity to inspect defective part or parts; material is still property of original owner; material is still part of the original installation operating under normal usage (eight hours per day and five days per week constitutes normal usage); and material is properly maintained and lubricated per factory instructions.

RICHARDS-WILCOX'S LIABILITY UNDER THIS WARRANTY, SHALL BE LIMITED TO FURNISHING A PART OR PARTS AS NECESSARY. ANY EXPENSE RELATIVE TO INSTALLATION SHALL NOT BE BORNE BY RICHARDS-WILCOX. EQUIPMENT DAMAGED AS A RESULT OF EXPOSURE TO CORROSIVE OR ABRASIVE SUBSTANCES, OR TEMPERATURES IN EXCESS OF 450 DEGREES FAHRENHEIT, SHALL NOT BE REPLACED UNDER THIS WARRANTY.

THE ABOVE WARRANTIES DO NOT COVER PARTS WHICH UPON INSPECTION ARE DETERMINED BY RICHARDS-WILCOX TO HAVE BEEN SUBJECTED TO MISUSE, NEGLIGENCE, ALTERATIONS, ACCIDENT, ABUSE, DAMAGE BY FIRE, FLOOD OR OTHER SIMILAR CASUALTY.

IN NO EVENT SHALL RICHARDS-WILCOX BE LIABLE FOR LIQUIDATED DAMAGES, OR INDIRECT OR CONSEQUENTIAL DAMAGES OF ANY NATURE.

Richards-Wilcox does not provide a separate warranty for parts or components not of its manufacture. The manufacturers of electrical motors and controls, air and hydraulic components and certain other items extend their own warranties, which Richards-Wilcox extends to Purchaser. Richards-Wilcox does not provide an extended warranty for electrical controls, sensors or cabling. Determination of warranty liability is subject to all conditions stated above.

This writing is intended by Richards-Wilcox to be a final expression of warranties. It is a complete and exclusive statement of the terms of said warranty. No course of prior dealings between Richards-Wilcox and purchaser, and no usage of trade shall be relevant to supplement or explain any term used in this warranty.

THIS WARRANTY IS IN LIEU OF ALL OTHER WARRANTIES, EXPRESSED OR IMPLIED, INCLUDING ANY WARRANTY OF MERCHANTABILITY, OR FITNESS FOR A PARTICULAR PURPOSE. THERE ARE NO WARRANTIES WHICH EXTEND BEYOND THE DESCRIPTION OF THE FACE HEREOF.



Richards-Wilcox, Inc.  
600 South Lake Street • Aurora, IL 60506  
Fax: 630-897-6994  
Toll Free: 888-852-1020

**[www.rwconveyor.com](http://www.rwconveyor.com)**

All Rights Reserved Copyright © 2019  
CONVCAT-1019



For more information go to:  
<http://www.rwconveyor.com/>