

**FOUR-WHEEL CARRIER**  
Part No. 2035.01718

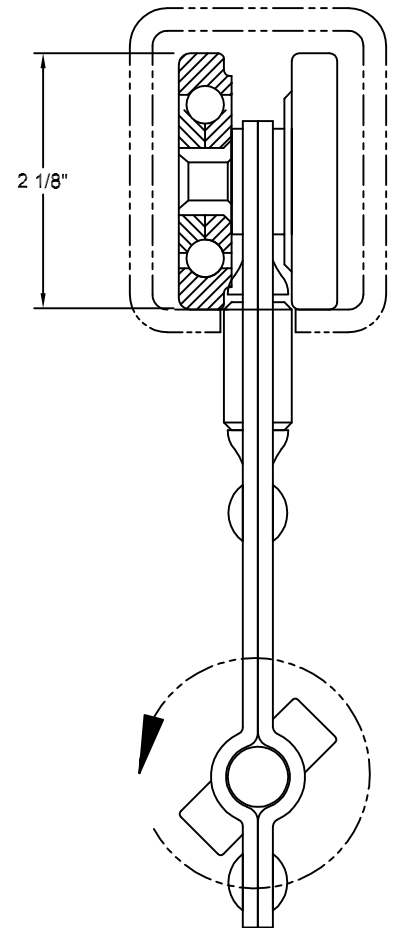
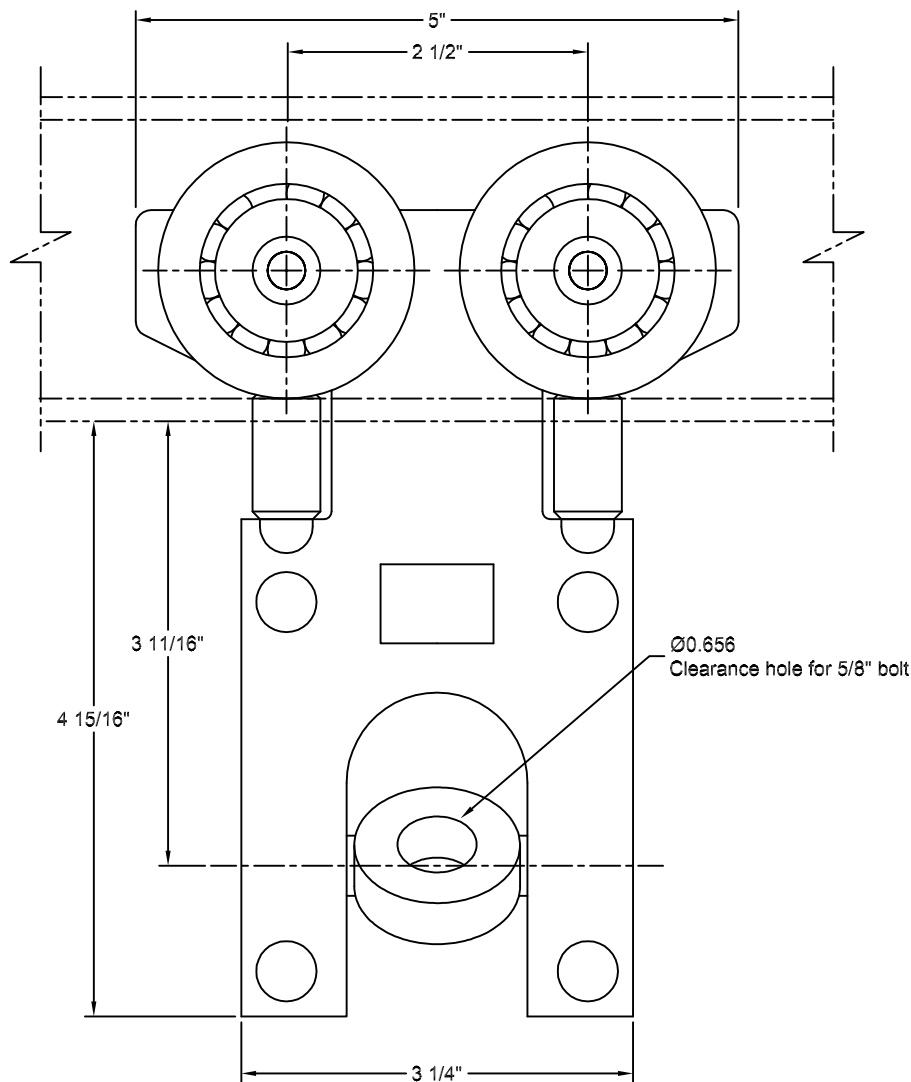

**DESCRIPTION:** The Four-Wheel Carrier is used for "Safe-Rail" applications. The carrier is equipped with hardened steel thrust rollers. The machined wheels are 2-1/8" in diameter and have a full compliment of steel ball bearings. The carrier side plates are zinc plated.

**APPLICATION:** This carrier is useable in portable tool systems. The carrier is used in all types of "Safe-Rail" applications with curves and switches.

**CAPACITY:** 250 lbs.

**SHIPPING WEIGHT:** 2.5 lbs.

**RICHARDS - WILCOX**

600 S LAKE ST. AURORA, IL 60506  
Phone: (630) 897-6951 Fax: (630) 897-6994  
Web Site: www.richardswilcox.com

DESCRIPTION:

**FOUR-WHEEL CARRIER**

PART NO.:

2035.01718

REV. LEVEL:

B

DATE:

JUNE 00

NOTICE:

This drawing in design and detail is the property of Richards-Wilcox, any reproductions of this print and/or design without the written consent of Richards-Wilcox is prohibited.

SR  
9