

CONVEYOR CHAIN LUBRICATOR

Part No. 2035.02893

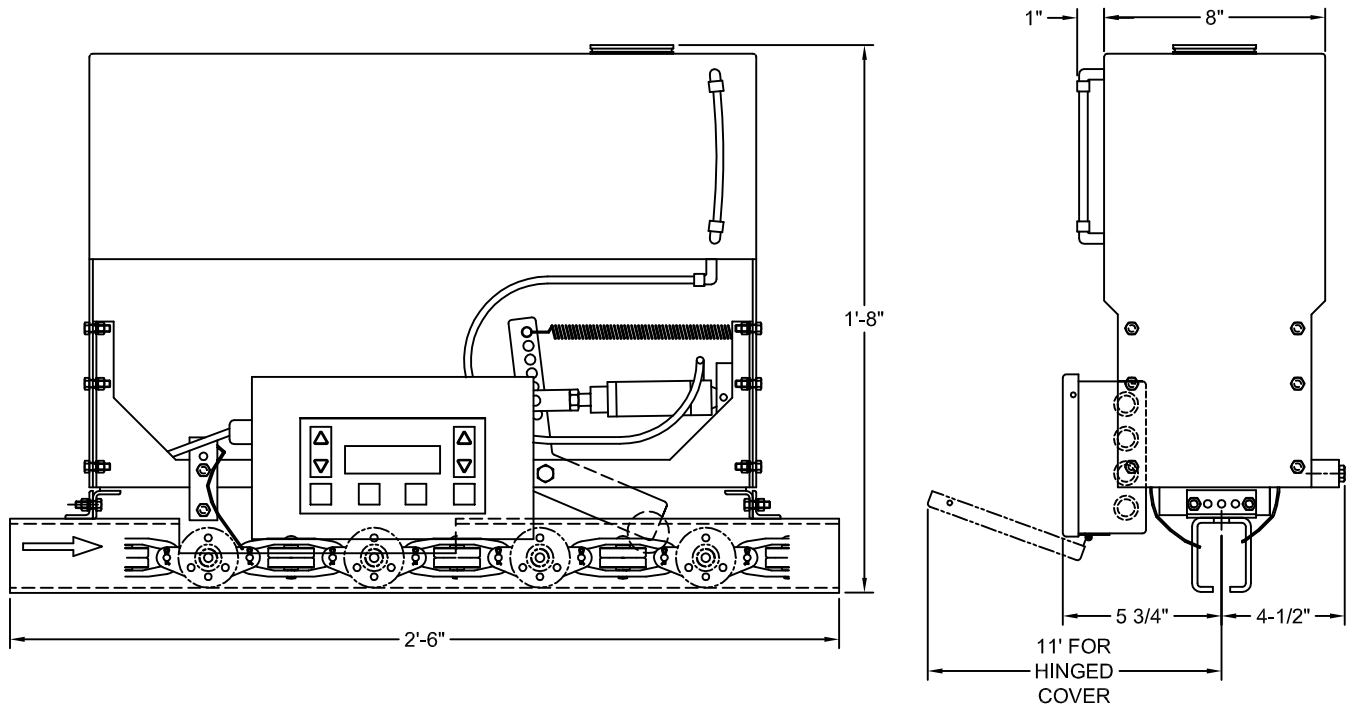

DESCRIPTION: The 2035.02893 Lubricator is designed to precisely lubricate the critical bearing points of the conveyor chain. The lubricator has five ejector tubes to precisely dispense the lubricant into the vertical and lateral wheel bearings along with the vertical link pin and roller. The unit has a micro-processor to accurately control the amount of lubricant that is dispensed.

APPLICATION: The 2035.02893 Lubricator is premounted onto a 2'-6" track section and has a 5.5 gallon reservoir with a low level alarm.
 Electrical requirements: 120VAC, 1 Amp.
 No air lines are required. No lubricant included.
 Lubricant must be purchased separately.

SHIPPING WEIGHT: 54 lbs.

RICHARDS - WILCOX

600 S LAKE ST. AURORA, IL 60506
 Phone: (630) 897-6951 Fax: (630) 897-6994
 Web Site: www.richardswilcox.com

DESCRIPTION:

CONVEYOR CHAIN LUBRICATOR

PART NO.:

2035.02893

REV. LEVEL:

A

DATE:

DEC 09

NOTICE:

This drawing in design and detail is the property of Richards-Wilcox, any reproductions of this print and/or design without the written consent of Richards-Wilcox is prohibited.

ZZ
39